

**A** Platten  
Plates  
Piastrre  
Plošče  
Desky

**B** Führungselemente  
Guide elements  
Elementi di guida  
Vodilni elementi  
Vodící díly

**C** Präzisionsteile  
Precision elements  
Elementi di precisione  
Precizni elementi  
Přesné díly

**D** Temperierelemente  
Elements for heating  
and cooling  
Elementi di raffreddamento  
Hladilni elementi  
Díly pro temperaci a chlazení

**E** Federelemente  
Springs & elastomers  
Molle ed elastomeri  
Vzmeti in elastomeri  
Pružiny a elastomery

**F** Zubehör  
Accessories  
Accessori  
Pripomočki  
Příslušenství

**G** Info

## A

## PLATTEN / PLATES / PIASTRE / PLOŠČE / DESKY

21-1



**Bestellbeispiel**  
Ordering example  
**Esempio d'ordine**  
Primer naročanja  
**Objednávkový vzor**

### INFO

21-2



**Stahlbeschreibung**  
Table of steels  
**Tabella dei acciai**  
Tabela jekel  
**Tabulka ocelí**

### INFO

21-3



**Toleranzen und Platten  
auf Anfrage**  
Tolerances and plates  
upon request  
**Tolleranze e piastre su richiesta**  
Tolerance in plošče na povpraševanje  
**Tolerance a desky na poptávku**

21-4 21-73

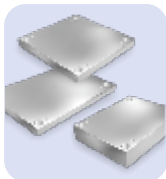

**Gebohrte Platten**  
Drilled plates  
**Piastre forate**  
Vrtane plošče  
**Vrtané desky**

21-74 21-91

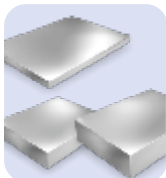

**Ungebohrte Platten**  
Grinded plates  
**Piastre rettificate**  
Brušene plošče  
**Nevrtané desky**

21-91

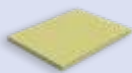

**Isolierplatten**  
Isolating plates  
**Piastre isolanti**  
Izolacijske plošče  
**Izolační desky**

## 21\_\_ H - A x B - s - mat.

|      |            |               |           |
|------|------------|---------------|-----------|
| TYP  | ABMESSUNG  | PLATTENSTÄRKE | WERKSTOFF |
| TYPE | DIMENZIONS | THICKNESS     | MATERIAL  |
| TIPO | DIMENSIONI | SPESSORE      | MATERIALE |
| TIP  | DIMENZIJE  | DEBELINA      | MATERIAL  |

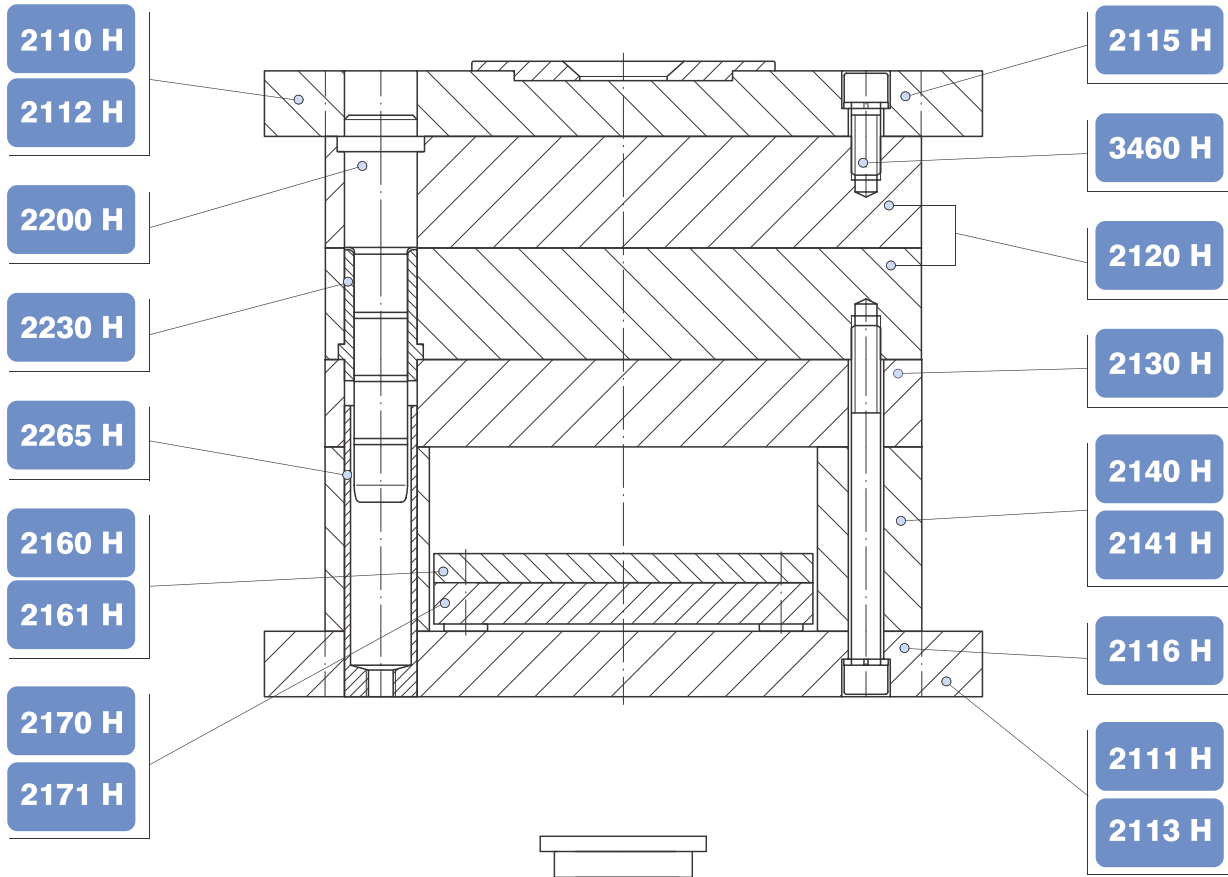

| Werkstoff Nr.<br>Material No.<br>Materiale No.<br>Material št. | DIN            | Richtanalyse<br>Compound (%)<br>Composizione<br>Sestava | Charakteristik, Festigkeit, Verwendungsbeispiele<br>Characteristic, Strength, Usage examples<br>Caratteristica, resistenza meccanica, esempi d'uso<br>Značilnosti, jakost, primeri uporabe |   |
|--|----------------|---|--|---|
| 1.1730   | C 45 W 3       | C   | 0,45   | <p>Unlegierter, Werkzeugstahl. Festigkeit ca. 640 N/mm<sup>2</sup>. Ungehärtete Bauteile im Formen-, Werkzeug- und Vorrichtungsbau.</p> <p>Non-alloyed steel, tensile strength up to 640 N/mm<sup>2</sup>. For construction parts subjected to low stress for moulds, dies and fixtures. Hardening, nitriding and polishing not common.</p> <p>Acciaio non legato con resistenza meccanica fino a 650N/mm<sup>2</sup>. L'uso è indicato per parti integranti di utensili e macchinari sottoposti a carichi minori. Non è indicato per il trattamento di tempra, la nitrurazione e la lucidatura.</p> <p>Nelegirano orodno jeklo trdnosti do 650 N/mm<sup>2</sup>. Uporaba za malo obremenjene sestavne dele orodij in naprav. Ni primerno za kaljenje, nitriranje in poliranje.</p>   |
|  |                | Si  | 0,30   |   |
|  |                | Mn  | 0,70   |   |
|  |                | Cr  | -  |   |
|  |                | Mo  | -  |   |
|  |                | Ni  | -  |   |
|  |                | S   | -  |   |
|  |                | V   | -  |   |
| 1.2162   | 21 MnCr 5      | C   | 0,21   | <p>Standard-Einsatzstahl. Festigkeit ca. 660 N/mm<sup>2</sup>. Formplatten und Einsätze für die Kunststoffverarbeitung.</p> <p>Case hardening steel, tensile strength on delivery up to 660 N/mm<sup>2</sup>. For cavity plates and inserts for moulds and other parts subjected to wear during operation.</p> <p>Acciaio da cementazione, durezza disponibile fino a 700 N/mm<sup>2</sup>. L'uso è indicato per dischi e inserti negli utensili per la plastica, per le parti esposte all'usura della superficie.</p> <p>Jeklo za cementacijo, dobavljiva trdnost do 700 N/mm<sup>2</sup>. Uporaba za plošče in vložke v orodjih za plastiko, za dele izpostavljene površinski obrabi.</p>   |
|  |                | Si  | 0,25   |   |
|  |                | Mn  | 1,25   |   |
|  |                | Cr  | 1,20   |   |
|  |                | Mo  | -  |   |
|  |                | Ni  | -  |   |
|  |                | S   | -  |   |
|  |                | V   | -  |   |
| 1.2767   | X 45 NiCrMo 4  | C   | 0,45   | <p>Spezial-Durchhärterstahl (hochpolierfähig). Festigkeit ca. 830 N/mm<sup>2</sup>. Formplatten und Einsätze für die Kunststoffverarbeitung. Bauteile mit hoher Druck und Biegefestigkeit, sowie Hochglanzpolituren.</p> <p>Through hardening steel, tensile strength on delivery up to 830 N/mm<sup>2</sup>. For cavity plates and inserts for moulds, for parts which need high compressive and bending strength. Suitable for high-gloss polish.</p> <p>Acciaio per la tempra, resistenza meccanica disponibile fino a 880N/mm<sup>2</sup>. L'uso è indicato per piastre e inserti nei portastampi per la plastica, per parti sottoposte a carichi maggiori di sollecitazioni di compressione e flessione. Ideale per la lucidatura con effetto molto splendente.</p> <p>Jeklo za kaljenje, dobavljiva trdnost do 880 N/mm<sup>2</sup>. Uporaba za plošče in vložke v orodjih za plastiko, za močno obremenjene dele na tlak in upogib. Primerno za poliranje z visokim sijajem.</p>   |
|  |                | Si  | 0,25   |   |
|  |                | Mn  | 0,40   |   |
|  |                | Cr  | 1,35   |   |
|  |                | Mo  | 0,25   |   |
|  |                | Ni  | 4,0  |   |
|  |                | S   | -  |   |
|  |                | V   | -  |   |
| 1.2083   | X 42 Cr 13     | C   | 0,42   | <p>Korrosionsbeständiger Durchhärterstahl. Festigkeit ca. 780 N/mm<sup>2</sup>. Formplatten und Einsätze für die Kunststoffverarbeitung, vorwiegend bei Verarbeitung chemisch aggressiver Kunststoffe.</p> <p>Corrosion-resistant through hardening steel, tensile strength on delivery up to 780N/mm<sup>2</sup>. For cavity plates and inserts for moulds, preferably used when processing chemically aggressive resins.</p> <p>Acciaio inossidabile da tempra, resistenza meccanica disponibile fino a 780 N/mm<sup>2</sup>. Indicato per l'uso per e inserti nei portastampi per la plastica, specialmente per la lavorazione di materiali chimicamente aggressivi.</p> <p>Nerjavno jeklo za kaljenje, dobavljiva trdnost do 780 N/mm<sup>2</sup>. Uporaba za plošče in vložke v orodjih za plastiko, predvsem pri predelavi kemično agresivnih plastičnih mas.</p>   |
|  |                | Si  | 0,40   |   |
|  |                | Mn  | 0,30   |   |
|  |                | Cr  | 13,0   |   |
|  |                | Mo  | -  |   |
|  |                | Ni  | -  |   |
|  |                | S   | -  |   |
|  |                | V   | -  |   |
| 1.2085   | X 33 CrS 16    | C   | 0,33   | <p>Korrosionsbeständiger vorvergüteter Edelstahl. Festigkeit ca. 1080 N/mm<sup>2</sup>. Formplatten für aggressive Kunststoffe und korrodierende Temperiermedien.</p> <p>Corrosion-resistant pre-hardened tool steel, tensile strength on delivery up to 1080N/mm<sup>2</sup>. For cavity plates and inserts for moulds, preferably used when processing chemically aggressive resins. Heat treatment is not required.</p> <p>Acciaio inossidabile, disponibile in stato bonificato della resistenza meccanica di 1000 N/mm<sup>2</sup>. Indicato per l'uso per piastre e inserti nei portastampi per la plastica, specialmente per la lavorazione di materiali chimicamente aggressivi. Il trattamento termico non è necessario.</p> <p>Nerjavno orodno jeklo, dobavljivo v poboljšanem stanju trdnosti do 1000 N/mm<sup>2</sup>. Uporaba za plošče in vložke v orodjih za plastiko, predvsem pri predelavi kemično agresivnih plastičnih mas. Toplotna obdelava ni potrebna.</p>  |
|  |                | Si  | 1,0  |   |
|  |                | Mn  | 1,0  |   |
|  |                | Cr  | 16,0   |   |
|  |                | Mo  | -  |   |
|  |                | Ni  | 1,0  |   |
|  |                | S   | 0,075  |   |
|  |                | P   | 0,03   |   |
| 1.2311   | 40 CrMnMo 7    | C   | 0,4  | <p>Vorvergüteter Werkzeugstahl. Festigkeit ca. 1080 N/mm<sup>2</sup>. Formplatten und Einsätze für die Kunststoffverarbeitung. Gut polierbar. Fotoätzen und Strukturerochieren möglich.</p> <p>Pre-hardened tool steel, tensile strength on delivery up to 1080 N/mm<sup>2</sup>. For cavity plates and inserts for moulds, good polishable, etching and structural eroding are practicable. For parts subject to high compressive strength, heat treatment is not required.</p> <p>Acciaio bonificato, resistenza meccanica disponibile fino a 1080N/mm<sup>2</sup>. Indicato per l'uso per piastre e inserti nei portastampi per la plastica, ideale per la lucidatura, la fotoincisione e l'elettroerosione. Indicato per l'uso su parti sottoposte a carichi maggiori, non è necessario il trattamento termico.</p> <p>Poboljšano orodno jeklo, dobavljiva trdnost do 1080 N/mm<sup>2</sup>. Uporaba za plošče in vložke v orodjih za plastiko, primerno za poliranje, fotograviranje in strukturno erodiranje. Uporaba za tlačno zelo obremenjene dele, ni potrebna toplotna obdelava.</p> |
|  |                | Si  | 0,3  |   |
|  |                | Mn  | 1,5  |   |
|  |                | Cr  | 1,9  |   |
|  |                | Mo  | 0,2  |   |
|  |                | Ni  | -  |   |
|  |                | S   | -  |   |
|  |                | V   | -  |   |
| 1.2312   | 40 CrMnMoS 8 6 | C   | 0,4  | <p>Vorvergüteter Werkzeugstahl (gut zerspanbar). Festigkeit ca. 1080 N/mm<sup>2</sup>. Formplatten für die Kunststoffverarbeitung. Formrahmen für Druck- und Spritzgießformen.</p> <p>Pre-hardened tool steel, tensile strength on delivery up to 1080 N/mm<sup>2</sup>. For cavity plates and inserts for moulds. For parts subject to high compressive strength, heat treatment is not required.</p> <p>Acciaio bonificato, resistenza meccanica disponibile fino a 1080N/mm<sup>2</sup>. Indicato per l'uso per piastre e inserti nei portastampi per la plastica. Indicato per l'uso su parti sottoposte a carichi maggiori, non è necessario il trattamento termico.</p> <p>Poboljšano orodno jeklo, dobavljiva trdnost do 1080 N/mm<sup>2</sup>. Uporaba za plošče in vložke v orodjih za plastiko. Uporaba za tlačno zelo obremenjene dele, ni potrebna toplotna obdelava.</p>   |
|  |                | Si  | 0,4  |   |
|  |                | Mn  | 1,5  |   |
|  |                | Cr  | 1,9  |   |
|  |                | Mo  | 0,2  |   |
|  |                | Ni  | -  |   |
|  |                | S   | 0,06   |   |
|  |                | V   | -  |   |
| 1.2343   | X 38 CrMoV 5 1 | C   | 0,38   | <p>Standard Warmarbeitsstahl. Festigkeit ca. 780 N/mm<sup>2</sup>. Formplatten und Einsätze für Al-, Mg- und Zn-Druckguß. Formplatten und Einsätze für die Kunststoffverarbeitung.</p> <p>High-alloy hot work steel, tensile strength on delivery up to 780 N/mm<sup>2</sup>. For cavity plates and inserts for plastics processing and for processing of Al, Mg and Zn alloys.</p> <p>Acciaio per lavorazione in caldo, resistenza meccanica disponibile fino a 700 N/mm<sup>2</sup>. Indicato per l'uso per piastre e inserti nei portastampi per la plastica, per la pressofusione dell'alluminio, del magnesio e delle leghe di zinco.</p> <p>Jeklo za delo v vročem, dobavljiva trdnost do 700 N/mm<sup>2</sup>. Uporaba za plošče in vložke v orodjih za plastiko, za plošče in vložke v orodjih za tlačni liv Al, Mg in Zn zlitin.</p>   |
|  |                | Si  | 1,0  |   |
|  |                | Mn  | 0,4  |   |
|  |                | Cr  | 5,3  |   |
|  |                | Mo  | 1,2  |   |
|  |                | Ni  | -  |   |
|  |                | S   | -  |   |
|  |                | V   | 0,4  |   |

## INFO

**Toleranzen und Platten auf Anfrage**  
Tolerances and plates upon request

**Tolleranze e piastre su richiesta**  
Dovljena odstopanja in plošče po naročilu

Toleranzen / Tolerances / Tolleranze / Dovljena odstopanja

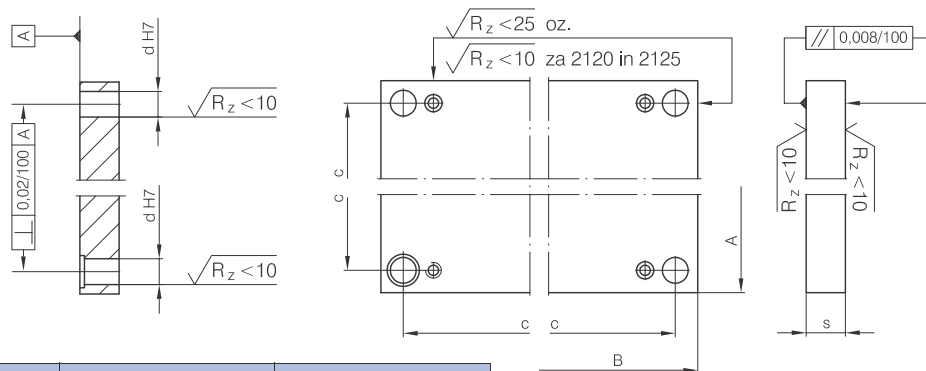

|          | mm        | $\mu\text{m}$   | $\mu\text{m}$ |
|----------|-----------|-----------------|---------------|
| <b>A</b> | -100      | $\pm 60$        | $\pm 8$       |
| <b>B</b> | 100 - 180 | $\pm 80$        | $\pm 10$      |
| <b>C</b> | 180 - 315 | $\pm 100$       | $\pm 12$      |
|          | 315 - 500 | $\pm 120$       | $\pm 14$      |
|          | 500 - 710 | $\pm 150$       | $\pm 17$      |
| <b>s</b> | 10 - 80   | $+50$ do $+150$ |               |



**2112 H**

Platten auf Anfrage  
Plates upon request  
Piastrre su richiesta  
Plošče na povpraševanje

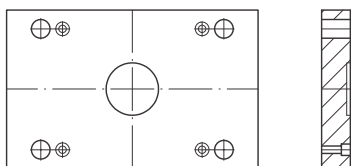

**2113 H**

Platten auf Anfrage  
Plates upon request  
Piastrre su richiesta  
Plošče na povpraševanje

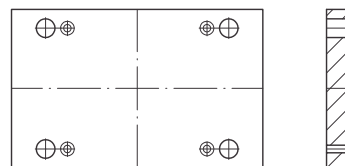

**2141 H**

Platten auf Anfrage  
Plates upon request  
Piastrre su richiesta  
Plošče na povpraševanje

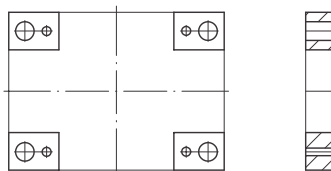

**2161 H**

Platten auf Anfrage  
Plates upon request  
Piastrre su richiesta  
Plošče na povpraševanje

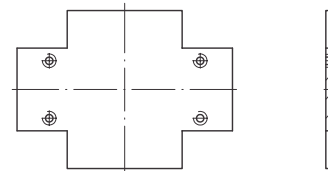

**2171 H**

Platten auf Anfrage  
Plates upon request  
Piastrre su richiesta  
Plošče na povpraševanje

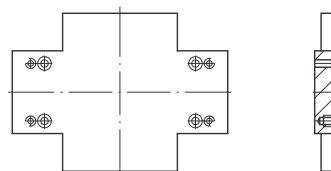

**2180 H**

Platten auf Anfrage  
Plates upon request  
Piastrre su richiesta  
Plošče na povpraševanje

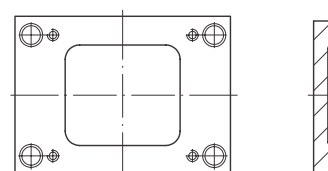

# 156 x 156

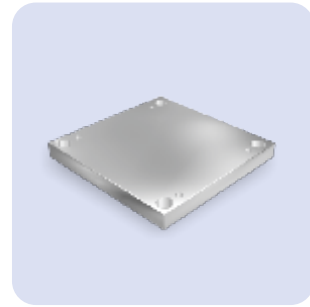
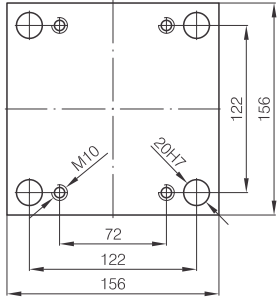

**2110 H**

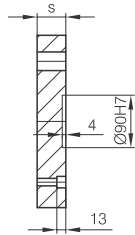
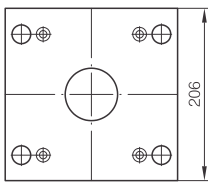

| S  | Material                 |                          |
|----|--------------------------|--------------------------|
|    | 1.1730                   | 1.2312                   |
| 22 | <input type="checkbox"/> | <input type="checkbox"/> |
| 27 | <input type="checkbox"/> | <input type="checkbox"/> |



**2111 H**

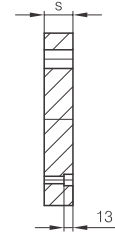
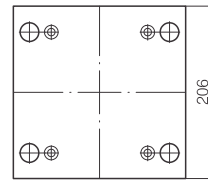

| S  | Material                 |                          |
|----|--------------------------|--------------------------|
|    | 1.1730                   | 1.2312                   |
| 22 | <input type="checkbox"/> | <input type="checkbox"/> |
| 27 | <input type="checkbox"/> | <input type="checkbox"/> |



**2115 H**

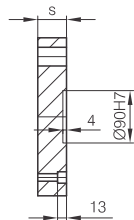
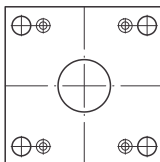

| S  | Material                 |                          |
|----|--------------------------|--------------------------|
|    | 1.1730                   | 1.2312                   |
| 17 | <input type="checkbox"/> | <input type="checkbox"/> |
| 22 | <input type="checkbox"/> | <input type="checkbox"/> |



**2116 H**

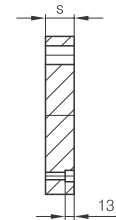
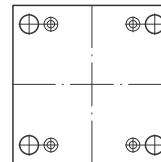

| S  | Material                 |                          |                          |
|----|--------------------------|--------------------------|--------------------------|
|    | 1.1730                   | 1.2162                   | 1.2312                   |
| 17 | <input type="checkbox"/> | <input type="checkbox"/> | <input type="checkbox"/> |
| 22 | <input type="checkbox"/> | <input type="checkbox"/> | <input type="checkbox"/> |



2120 H

2125 H

# 156 x 156

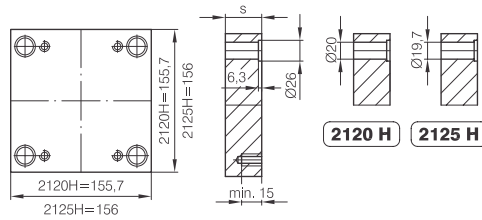

| S  | Material |        |        |        |        |        |        |        |
|----|----------|--------|--------|--------|--------|--------|--------|--------|
|    | 1.1730   | 1.2162 | 1.2767 | 1.2083 | 1.2085 | 1.2311 | 1.2312 | 1.2343 |
| 17 | ■        | ■      | ■      |        | ■      | ■      | ■      |        |
| 22 | ■        | ■      | ■      |        | ■      | ■      | ■      |        |
| 27 | ■        | ■      | ■      | ■      | ■      | ■      | ■      | ■      |
| 36 | ■        | ■      | ■      | ■      | ■      | ■      | ■      | ■      |
| 46 | ■        | ■      | ■      | ■      | ■      | ■      | ■      | ■      |
| 56 | ■        | ■      | ■      | ■      | ■      | ■      | ■      | ■      |
| 66 | ■        | ■      | ■      | ■      | ■      | ■      | ■      | ■      |
| 76 | ■        | ■      | ■      | ■      | ■      | ■      | ■      | ■      |



2130 H



2140 H

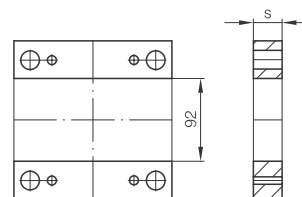
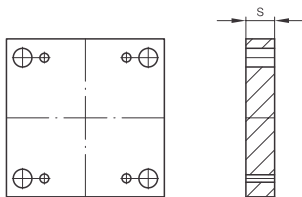

| S  | Material |        |
|----|----------|--------|
|    | 1.1730   | 1.2312 |
| 27 | ■        | ■      |
| 36 | ■        | ■      |

| S  | Material |        |
|----|----------|--------|
|    | 1.1730   | 1.2312 |
| 46 | ■        |        |
| 56 | ■        |        |
| 76 | ■        |        |



2160 H



2170 H

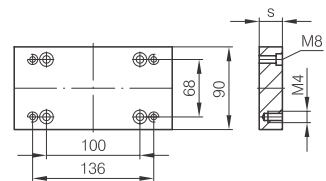
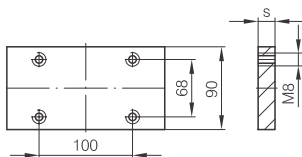

| S | Material |        |
|---|----------|--------|
|   | 1.1730   | 1.2312 |
| 9 | ■        |        |

| S  | Material |        |
|----|----------|--------|
|    | 1.1730   | 1.2312 |
| 17 | ■        | ■      |

# 156 x 196

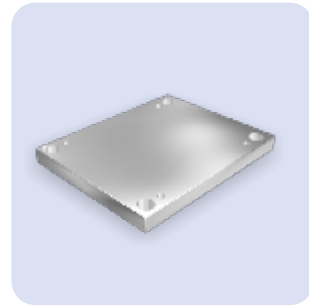
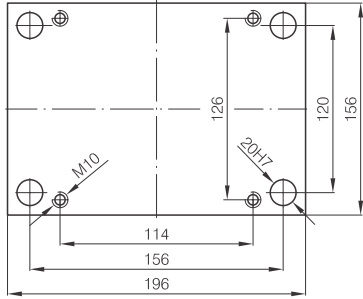

**2110 H**

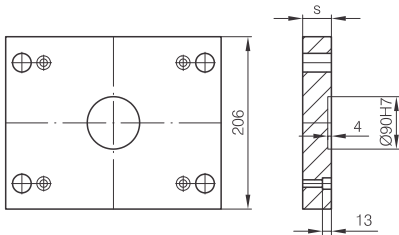

| S  | Material                 |                          |
|----|--------------------------|--------------------------|
|    | 1.1730                   | 1.2312                   |
| 22 | <input type="checkbox"/> | <input type="checkbox"/> |
| 27 | <input type="checkbox"/> | <input type="checkbox"/> |



**2111 H**

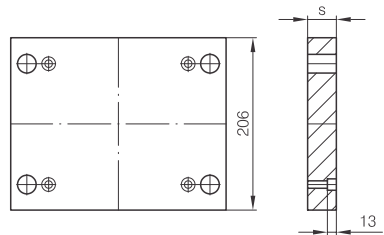

| S  | Material                 |                          |
|----|--------------------------|--------------------------|
|    | 1.1730                   | 1.2312                   |
| 22 | <input type="checkbox"/> | <input type="checkbox"/> |
| 27 | <input type="checkbox"/> | <input type="checkbox"/> |



**2115 H**

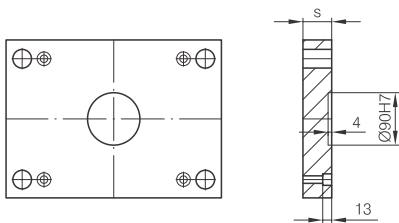

| S  | Material                 |                          |
|----|--------------------------|--------------------------|
|    | 1.1730                   | 1.2312                   |
| 17 | <input type="checkbox"/> | <input type="checkbox"/> |
| 22 | <input type="checkbox"/> | <input type="checkbox"/> |



**2116 H**

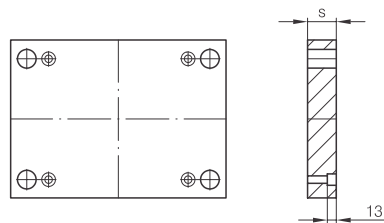

| S  | Material                 |                          |                          |
|----|--------------------------|--------------------------|--------------------------|
|    | 1.1730                   | 1.2162                   | 1.2312                   |
| 17 | <input type="checkbox"/> | <input type="checkbox"/> | <input type="checkbox"/> |
| 22 | <input type="checkbox"/> | <input type="checkbox"/> | <input type="checkbox"/> |



2120 H

2125 H

# 156 x 196

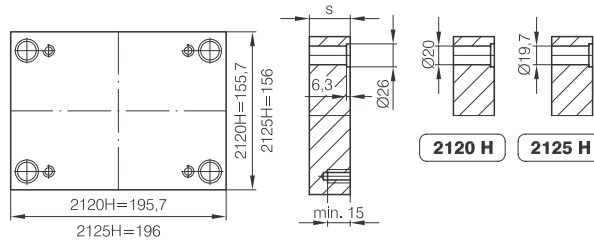

| S  | Material |        |        |        |        |        |        |        |
|----|----------|--------|--------|--------|--------|--------|--------|--------|
|    | 1.1730   | 1.2162 | 1.2767 | 1.2083 | 1.2085 | 1.2311 | 1.2312 | 1.2343 |
| 17 | ■        | ■      | ■      |        | ■      | ■      | ■      |        |
| 22 | ■        | ■      | ■      |        | ■      | ■      | ■      |        |
| 27 | ■        | ■      | ■      | ■      | ■      | ■      | ■      | ■      |
| 36 | ■        | ■      | ■      | ■      | ■      | ■      | ■      | ■      |
| 46 | ■        | ■      | ■      | ■      | ■      | ■      | ■      | ■      |
| 56 | ■        | ■      | ■      | ■      | ■      | ■      | ■      | ■      |
| 66 | ■        | ■      | ■      | ■      | ■      | ■      | ■      | ■      |
| 76 | ■        | ■      | ■      | ■      | ■      | ■      | ■      | ■      |



2130 H



2140 H

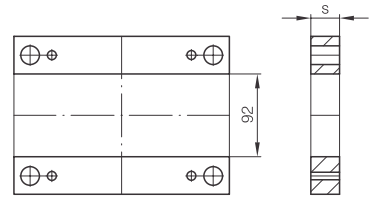
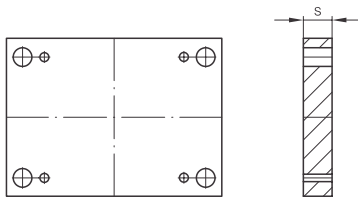

| S  | Material |        |
|----|----------|--------|
|    | 1.1730   | 1.2312 |
| 27 | ■        | ■      |
| 36 | ■        | ■      |

| S  | Material |        |
|----|----------|--------|
|    | 1.1730   | 1.2312 |
| 46 | ■        |        |
| 56 | ■        |        |
| 76 | ■        |        |



2160 H



2170 H

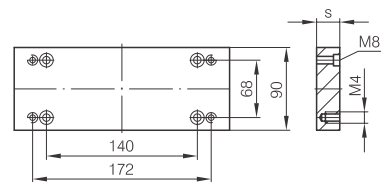
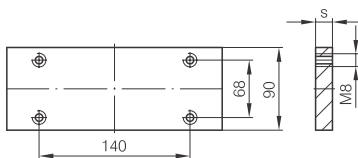

| S | Material |        |
|---|----------|--------|
|   | 1.1730   | 1.2312 |
| 9 | ■        |        |

| S  | Material |        |
|----|----------|--------|
|    | 1.1730   | 1.2312 |
| 17 | ■        |        |

# 156 x 246

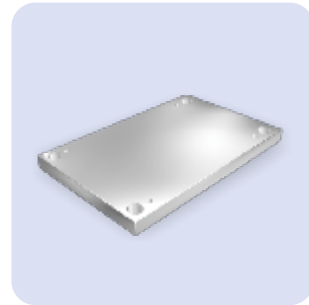
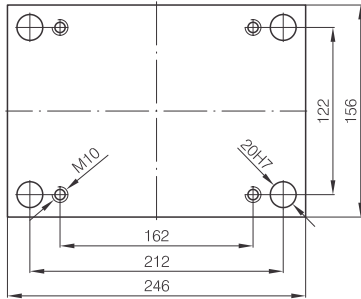

**2110 H**

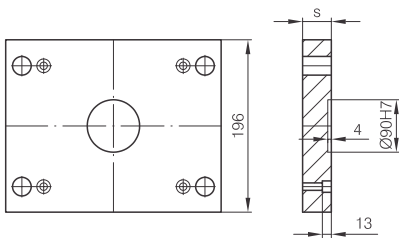

| S  | Material                 |                          |
|----|--------------------------|--------------------------|
|    | 1.1730                   | 1.2312                   |
| 22 | <input type="checkbox"/> | <input type="checkbox"/> |
| 27 | <input type="checkbox"/> | <input type="checkbox"/> |



**2111 H**

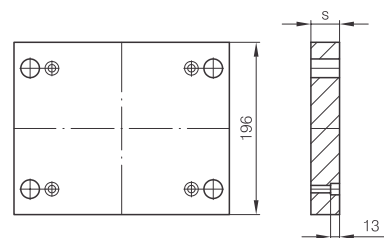

| S  | Material                 |                          |
|----|--------------------------|--------------------------|
|    | 1.1730                   | 1.2312                   |
| 22 | <input type="checkbox"/> | <input type="checkbox"/> |
| 27 | <input type="checkbox"/> | <input type="checkbox"/> |



**2115 H**

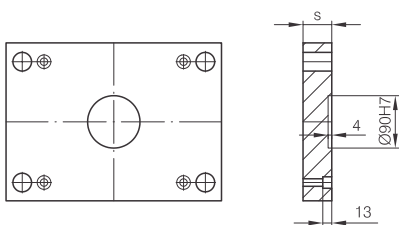

| S  | Material                 |                          |
|----|--------------------------|--------------------------|
|    | 1.1730                   | 1.2312                   |
| 17 | <input type="checkbox"/> | <input type="checkbox"/> |
| 22 | <input type="checkbox"/> | <input type="checkbox"/> |



**2116 H**

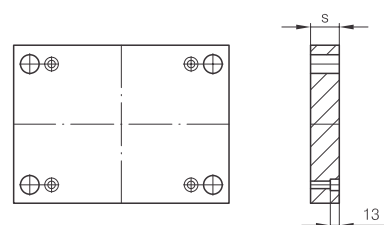

| S  | Material                 |                          |                          |
|----|--------------------------|--------------------------|--------------------------|
|    | 1.1730                   | 1.2162                   | 1.2312                   |
| 17 | <input type="checkbox"/> | <input type="checkbox"/> | <input type="checkbox"/> |
| 22 | <input type="checkbox"/> | <input type="checkbox"/> | <input type="checkbox"/> |



2120 H

2125 H

## 156 x 246

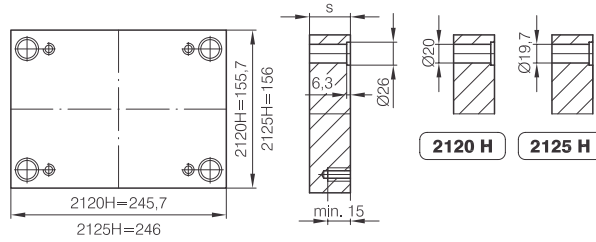

| S  | Material |        |        |        |        |        |        |        |
|----|----------|--------|--------|--------|--------|--------|--------|--------|
|    | 1.1730   | 1.2162 | 1.2767 | 1.2083 | 1.2085 | 1.2311 | 1.2312 | 1.2343 |
| 17 | ■        | ■      | ■      |        | ■      | ■      | ■      |        |
| 22 | ■        | ■      | ■      |        | ■      | ■      | ■      |        |
| 27 | ■        | ■      | ■      | ■      | ■      | ■      | ■      | ■      |
| 36 | ■        | ■      | ■      | ■      | ■      | ■      | ■      | ■      |
| 46 | ■        | ■      | ■      | ■      | ■      | ■      | ■      | ■      |
| 56 | ■        | ■      | ■      | ■      | ■      | ■      | ■      | ■      |
| 66 | ■        | ■      | ■      | ■      | ■      | ■      | ■      | ■      |
| 76 | ■        | ■      | ■      | ■      | ■      | ■      | ■      | ■      |



2130 H



2140 H

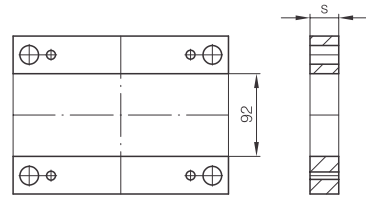
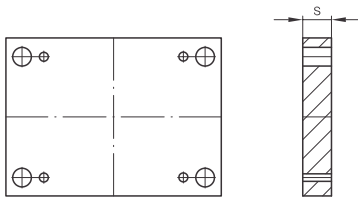

| S  | Material |        |
|----|----------|--------|
|    | 1.1730   | 1.2312 |
| 27 | ■        | ■      |
| 36 | ■        | ■      |

| S  | Material |        |
|----|----------|--------|
|    | 1.1730   | 1.2312 |
| 46 | ■        |        |
| 56 | ■        |        |
| 76 | ■        |        |



2160 H



2170 H

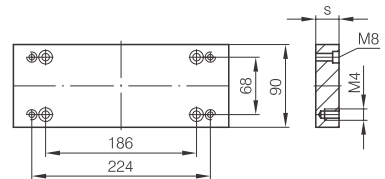
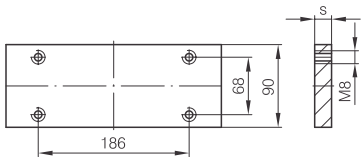

| S | Material |        |
|---|----------|--------|
|   | 1.1730   | 1.2312 |
| 9 | ■        |        |

| S  | Material |        |
|----|----------|--------|
|    | 1.1730   | 1.2312 |
| 17 | ■        | ■      |

# 196 x 196

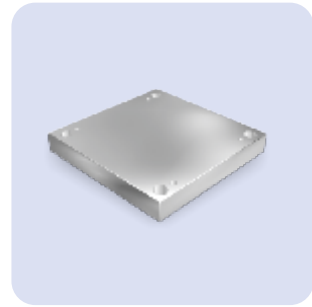
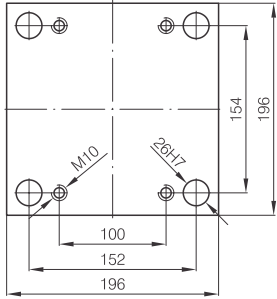

**2110 H**

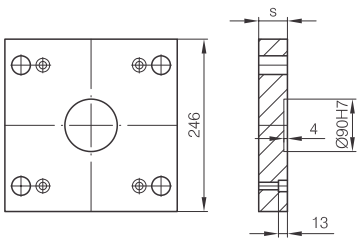

| S  | Material                 |                          |
|----|--------------------------|--------------------------|
|    | 1.1730                   | 1.2312                   |
| 22 | <input type="checkbox"/> | <input type="checkbox"/> |
| 27 | <input type="checkbox"/> | <input type="checkbox"/> |



**2111 H**

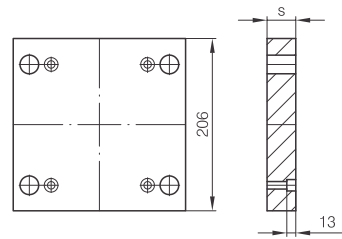

| S  | Material                 |                          |
|----|--------------------------|--------------------------|
|    | 1.1730                   | 1.2312                   |
| 22 | <input type="checkbox"/> | <input type="checkbox"/> |
| 27 | <input type="checkbox"/> | <input type="checkbox"/> |



**2115 H**

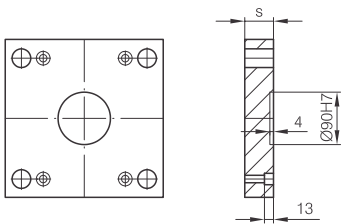

| S  | Material                 |                          |
|----|--------------------------|--------------------------|
|    | 1.1730                   | 1.2312                   |
| 17 | <input type="checkbox"/> | <input type="checkbox"/> |
| 22 | <input type="checkbox"/> | <input type="checkbox"/> |



**2116 H**

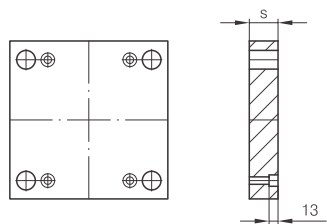

| S  | Material                 |                          |                          |
|----|--------------------------|--------------------------|--------------------------|
|    | 1.1730                   | 1.2162                   | 1.2312                   |
| 17 | <input type="checkbox"/> | <input type="checkbox"/> | <input type="checkbox"/> |
| 22 | <input type="checkbox"/> | <input type="checkbox"/> | <input type="checkbox"/> |



2120 H

2125 H

# 196 x 196

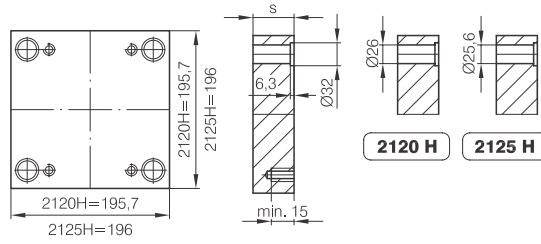

| S  | Material |        |        |        |        |        |        |        |
|----|----------|--------|--------|--------|--------|--------|--------|--------|
|    | 1.1730   | 1.2162 | 1.2767 | 1.2083 | 1.2085 | 1.2311 | 1.2312 | 1.2343 |
| 17 | ■        | ■      | ■      |        | ■      | ■      | ■      |        |
| 22 | ■        | ■      | ■      |        | ■      | ■      | ■      |        |
| 27 | ■        | ■      | ■      | ■      | ■      | ■      | ■      | ■      |
| 36 | ■        | ■      | ■      | ■      | ■      | ■      | ■      | ■      |
| 46 | ■        | ■      | ■      | ■      | ■      | ■      | ■      | ■      |
| 56 | ■        | ■      | ■      | ■      | ■      | ■      | ■      | ■      |
| 66 | ■        | ■      | ■      | ■      | ■      | ■      | ■      | ■      |
| 76 | ■        | ■      | ■      | ■      | ■      | ■      | ■      | ■      |
| 86 | ■        | ■      | ■      | ■      | ■      | ■      | ■      | ■      |
| 96 | ■        | ■      | ■      | ■      | ■      | ■      | ■      | ■      |



2130 H

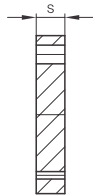
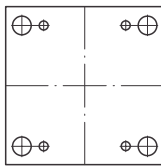

| S  | Material |        |
|----|----------|--------|
|    | 1.1730   | 1.2312 |
| 27 | ■        | ■      |
| 36 | ■        | ■      |



2140 H

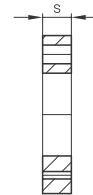
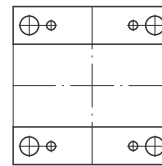

| S  | Material |        |
|----|----------|--------|
|    | 1.1730   | 1.2312 |
| 46 | ■        |        |
| 56 | ■        |        |
| 76 | ■        |        |



2160 H

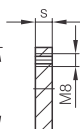
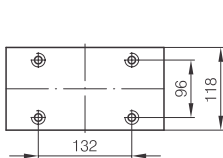

| S  | Material |        |
|----|----------|--------|
|    | 1.1730   | 1.2312 |
| 12 | ■        |        |



2170 H

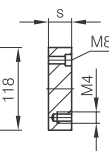
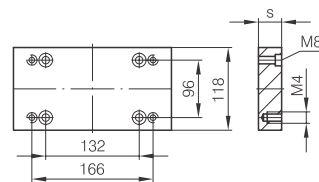

| S  | Material |        |
|----|----------|--------|
|    | 1.1730   | 1.2312 |
| 17 | ■        | ■      |

# 190 x 246

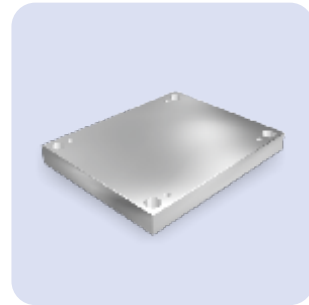
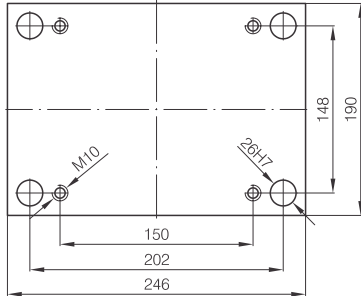

**2110 H**

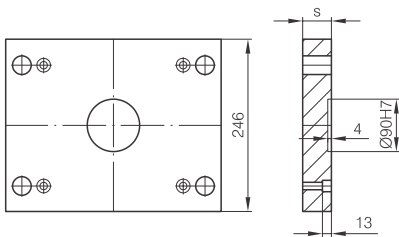

| S  | Material                            |                                     |
|----|-------------------------------------|-------------------------------------|
|    | 1.1730                              | 1.2312                              |
| 22 | <input checked="" type="checkbox"/> | <input checked="" type="checkbox"/> |
| 27 | <input checked="" type="checkbox"/> | <input checked="" type="checkbox"/> |



**2111 H**

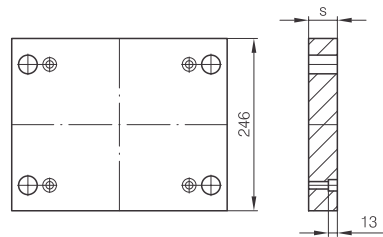

| S  | Material                            |                                     |
|----|-------------------------------------|-------------------------------------|
|    | 1.1730                              | 1.2312                              |
| 22 | <input checked="" type="checkbox"/> | <input checked="" type="checkbox"/> |
| 27 | <input checked="" type="checkbox"/> | <input checked="" type="checkbox"/> |



**2115 H**

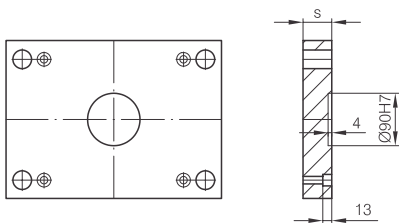

| S  | Material                            |                                     |
|----|-------------------------------------|-------------------------------------|
|    | 1.1730                              | 1.2312                              |
| 17 | <input checked="" type="checkbox"/> | <input checked="" type="checkbox"/> |
| 22 | <input checked="" type="checkbox"/> | <input checked="" type="checkbox"/> |



**2116 H**

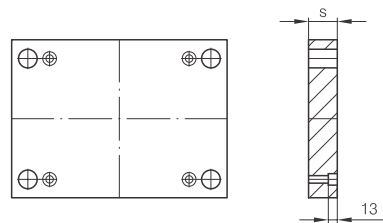

| S  | Material                            |                                     |                                     |
|----|-------------------------------------|-------------------------------------|-------------------------------------|
|    | 1.1730                              | 1.2162                              | 1.2312                              |
| 17 | <input checked="" type="checkbox"/> | <input checked="" type="checkbox"/> | <input checked="" type="checkbox"/> |
| 22 | <input checked="" type="checkbox"/> | <input type="checkbox"/>            | <input checked="" type="checkbox"/> |



2120 H

2125 H

## 190 x 246

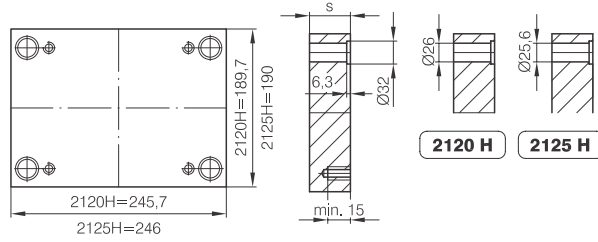

| S  | Material |        |        |        |        |        |        |        |
|----|----------|--------|--------|--------|--------|--------|--------|--------|
|    | 1.1730   | 1.2162 | 1.2767 | 1.2083 | 1.2085 | 1.2311 | 1.2312 | 1.2343 |
| 17 | ■        | ■      | ■      |        | ■      | ■      | ■      |        |
| 22 | ■        | ■      | ■      |        | ■      | ■      | ■      |        |
| 27 | ■        | ■      | ■      | ■      | ■      | ■      | ■      | ■      |
| 36 | ■        | ■      | ■      | ■      | ■      | ■      | ■      | ■      |
| 46 | ■        | ■      | ■      | ■      | ■      | ■      | ■      | ■      |
| 56 | ■        | ■      | ■      | ■      | ■      | ■      | ■      | ■      |
| 66 | ■        | ■      | ■      | ■      | ■      | ■      | ■      | ■      |
| 76 | ■        | ■      | ■      | ■      | ■      | ■      | ■      | ■      |
| 86 | ■        | ■      | ■      | ■      | ■      | ■      | ■      | ■      |
| 96 | ■        | ■      | ■      | ■      | ■      | ■      | ■      | ■      |



2130 H



2140 H

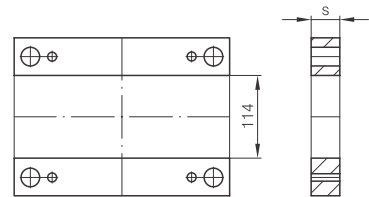
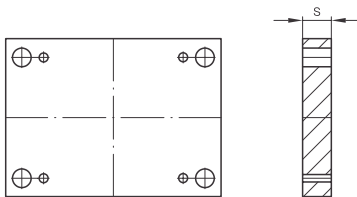

| S  | Material |        |
|----|----------|--------|
|    | 1.1730   | 1.2312 |
| 27 | ■        | ■      |
| 36 | ■        | ■      |

| S  | Material |        |
|----|----------|--------|
|    | 1.1730   | 1.2312 |
| 46 | ■        |        |
| 56 | ■        |        |
| 76 | ■        |        |



2160 H



2170 H

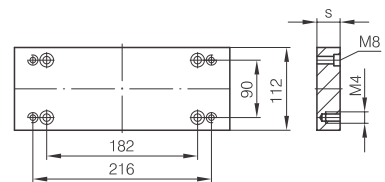
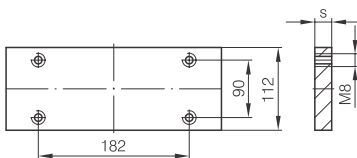

| S  | Material |        |
|----|----------|--------|
|    | 1.1730   | 1.2312 |
| 12 | ■        |        |

| S  | Material |        |
|----|----------|--------|
|    | 1.1730   | 1.2312 |
| 17 | ■        | ■      |

# 196 x 296

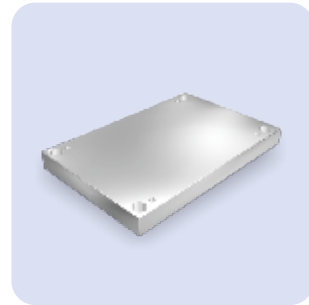
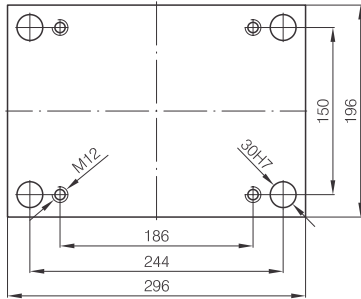

**2110 H**

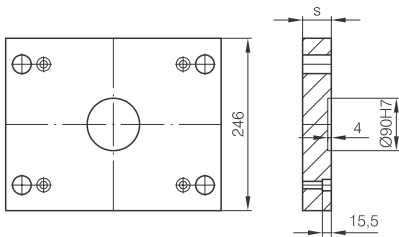

| S  | Material                            |                                     |
|----|-------------------------------------|-------------------------------------|
|    | 1.1730                              | 1.2312                              |
| 27 | <input checked="" type="checkbox"/> | <input checked="" type="checkbox"/> |
| 36 | <input checked="" type="checkbox"/> | <input checked="" type="checkbox"/> |



**2111 H**

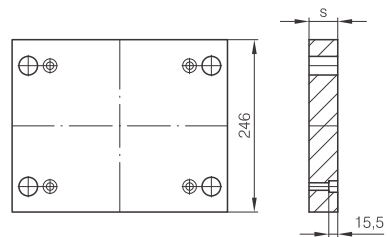

| S  | Material                            |                                     |
|----|-------------------------------------|-------------------------------------|
|    | 1.1730                              | 1.2312                              |
| 27 | <input checked="" type="checkbox"/> | <input checked="" type="checkbox"/> |
| 36 | <input checked="" type="checkbox"/> | <input checked="" type="checkbox"/> |



**2115 H**

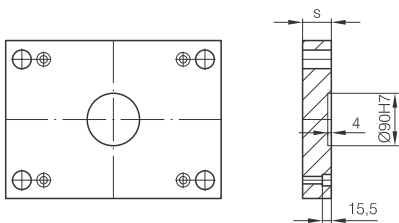

| S  | Material                            |                                     |
|----|-------------------------------------|-------------------------------------|
|    | 1.1730                              | 1.2312                              |
| 22 | <input checked="" type="checkbox"/> | <input checked="" type="checkbox"/> |
| 27 | <input checked="" type="checkbox"/> | <input checked="" type="checkbox"/> |



**2116 H**

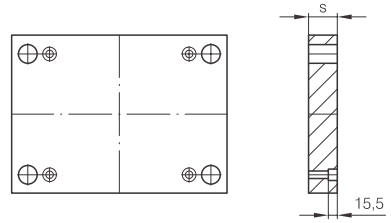

| S  | Material                            |                                     |                                     |
|----|-------------------------------------|-------------------------------------|-------------------------------------|
|    | 1.1730                              | 1.2162                              | 1.2312                              |
| 17 | <input checked="" type="checkbox"/> | <input checked="" type="checkbox"/> |                                     |
| 22 | <input checked="" type="checkbox"/> |                                     | <input checked="" type="checkbox"/> |
| 27 | <input checked="" type="checkbox"/> |                                     | <input checked="" type="checkbox"/> |



2120 H

2125 H

# 196 x 296

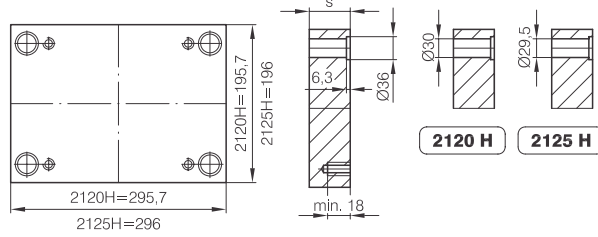

| S  | Material |        |        |        |        |        |        |        |
|----|----------|--------|--------|--------|--------|--------|--------|--------|
|    | 1.1730   | 1.2162 | 1.2767 | 1.2083 | 1.2085 | 1.2311 | 1.2312 | 1.2343 |
| 17 | ■        | ■      | ■      |        | ■      | ■      | ■      |        |
| 22 | ■        | ■      | ■      |        | ■      | ■      | ■      |        |
| 27 | ■        | ■      | ■      | ■      | ■      | ■      | ■      | ■      |
| 36 | ■        | ■      | ■      | ■      | ■      | ■      | ■      | ■      |
| 46 | ■        | ■      | ■      | ■      | ■      | ■      | ■      | ■      |
| 56 | ■        | ■      | ■      | ■      | ■      | ■      | ■      | ■      |
| 66 | ■        | ■      | ■      | ■      | ■      | ■      | ■      | ■      |
| 76 | ■        | ■      | ■      | ■      | ■      | ■      | ■      | ■      |
| 86 | ■        | ■      | ■      | ■      | ■      | ■      | ■      | ■      |
| 96 | ■        | ■      | ■      | ■      | ■      | ■      | ■      | ■      |



2130 H



2140 H

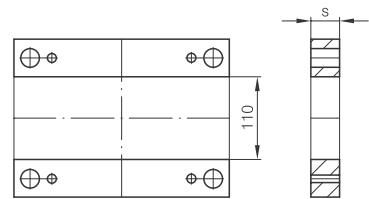
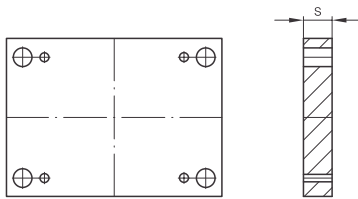

| S  | Material |        |
|----|----------|--------|
|    | 1.1730   | 1.2312 |
| 36 | ■        | ■      |

| S  | Material |        |
|----|----------|--------|
|    | 1.1730   | 1.2312 |
| 56 | ■        |        |
| 76 | ■        |        |
| 96 | ■        |        |



2160 H



2170 H

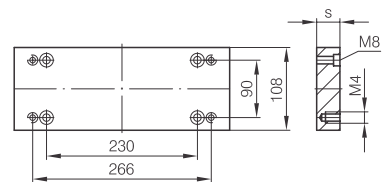
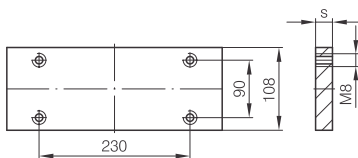

| S  | Material |        |
|----|----------|--------|
|    | 1.1730   | 1.2312 |
| 12 | ■        |        |

| S  | Material |        |
|----|----------|--------|
|    | 1.1730   | 1.2312 |
| 17 | ■        | ■      |

# 246 x 246

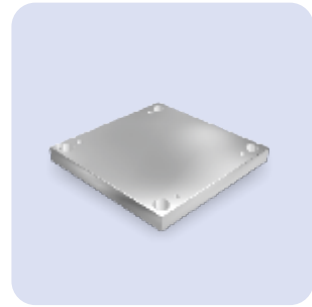
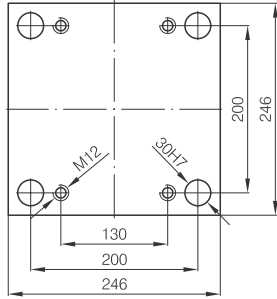

**2110 H**

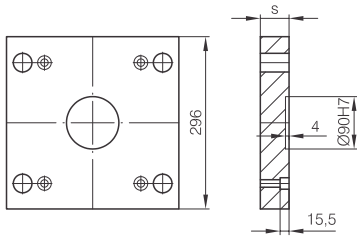

| S  | Material                 |                          |
|----|--------------------------|--------------------------|
|    | 1.1730                   | 1.2312                   |
| 27 | <input type="checkbox"/> | <input type="checkbox"/> |
| 36 | <input type="checkbox"/> | <input type="checkbox"/> |



**2111 H**

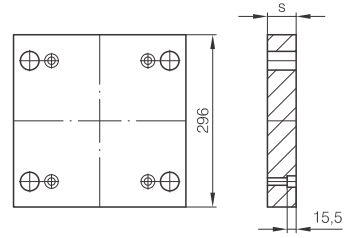

| S  | Material                 |                          |
|----|--------------------------|--------------------------|
|    | 1.1730                   | 1.2312                   |
| 27 | <input type="checkbox"/> | <input type="checkbox"/> |
| 36 | <input type="checkbox"/> | <input type="checkbox"/> |



**2115 H**

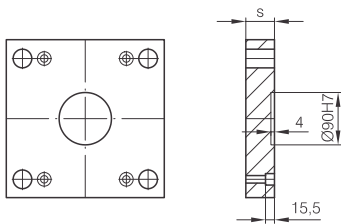

| S  | Material                 |                          |
|----|--------------------------|--------------------------|
|    | 1.1730                   | 1.2312                   |
| 22 | <input type="checkbox"/> | <input type="checkbox"/> |
| 27 | <input type="checkbox"/> | <input type="checkbox"/> |



**2116 H**

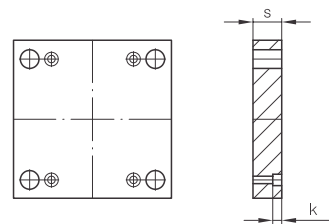

| S  | Material                 |                          |                          |
|----|--------------------------|--------------------------|--------------------------|
|    | 1.1730                   | 1.2162                   | 1.2312                   |
| 17 | <input type="checkbox"/> | <input type="checkbox"/> |                          |
| 22 | <input type="checkbox"/> |                          | <input type="checkbox"/> |
| 27 | <input type="checkbox"/> |                          | <input type="checkbox"/> |



2120 H

2125 H

## 246 x 246

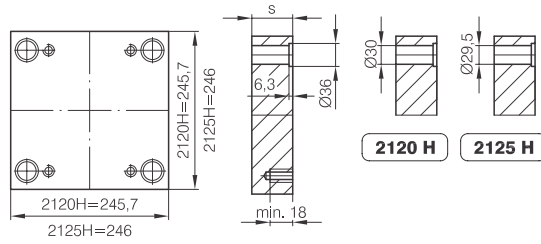

| S  | Material |        |        |        |        |        |        |        |
|----|----------|--------|--------|--------|--------|--------|--------|--------|
|    | 1.1730   | 1.2162 | 1.2767 | 1.2083 | 1.2085 | 1.2311 | 1.2312 | 1.2343 |
| 17 | ■        | ■      | ■      |        | ■      | ■      | ■      |        |
| 22 | ■        | ■      | ■      |        | ■      | ■      | ■      |        |
| 27 | ■        | ■      | ■      |        | ■      | ■      | ■      | ■      |
| 36 | ■        | ■      | ■      |        | ■      | ■      | ■      | ■      |
| 46 | ■        | ■      | ■      |        | ■      | ■      | ■      | ■      |
| 56 | ■        | ■      | ■      |        | ■      | ■      | ■      | ■      |
| 66 | ■        | ■      | ■      |        | ■      | ■      | ■      | ■      |
| 76 | ■        | ■      | ■      |        | ■      | ■      | ■      | ■      |
| 86 | ■        | ■      | ■      |        | ■      | ■      | ■      | ■      |
| 96 | ■        | ■      | ■      |        | ■      | ■      | ■      | ■      |



2130 H



2140 H

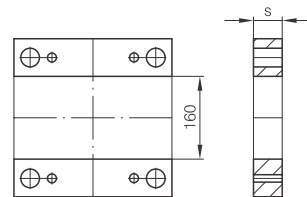
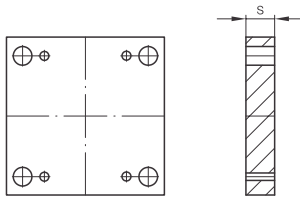

| S  | Material |        |
|----|----------|--------|
|    | 1.1730   | 1.2312 |
| 36 | ■        | ■      |

| S  | Material |        |
|----|----------|--------|
|    | 1.1730   | 1.2312 |
| 56 | ■        |        |
| 76 | ■        |        |
| 96 | ■        |        |



2160 H



2170 H

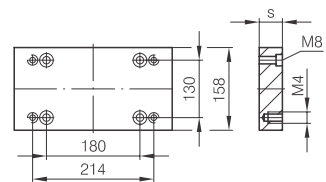
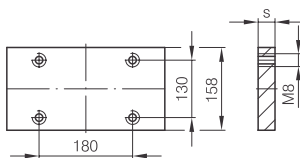

| S  | Material |        |
|----|----------|--------|
|    | 1.1730   | 1.2312 |
| 12 | ■        |        |

| S  | Material |        |
|----|----------|--------|
|    | 1.1730   | 1.2312 |
| 17 | ■        | ■      |

# 246 x 296

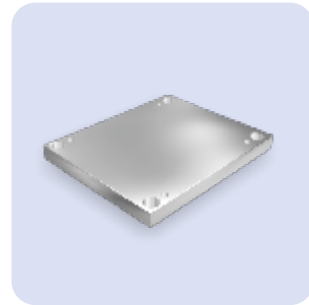
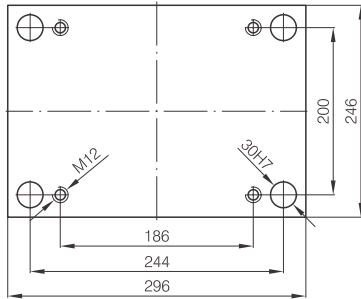

**2110 H**

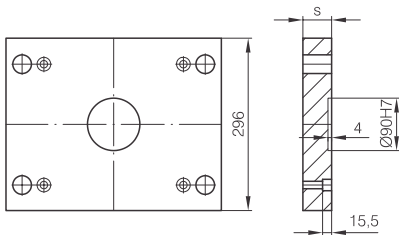

| S  | Material                 |                          |
|----|--------------------------|--------------------------|
|    | 1.1730                   | 1.2312                   |
| 27 | <input type="checkbox"/> | <input type="checkbox"/> |
| 36 | <input type="checkbox"/> | <input type="checkbox"/> |



**2111 H**

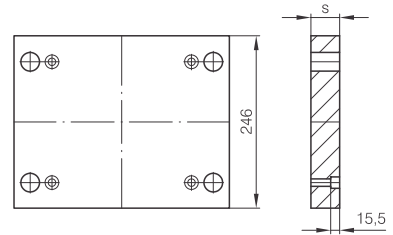

| S  | Material                 |                          |
|----|--------------------------|--------------------------|
|    | 1.1730                   | 1.2312                   |
| 27 | <input type="checkbox"/> | <input type="checkbox"/> |
| 36 | <input type="checkbox"/> | <input type="checkbox"/> |



**2115 H**

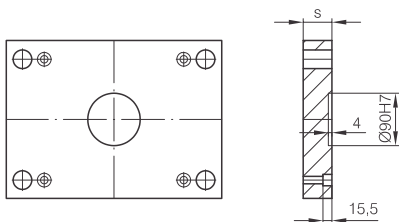

| S  | Material                 |                          |
|----|--------------------------|--------------------------|
|    | 1.1730                   | 1.2312                   |
| 22 | <input type="checkbox"/> | <input type="checkbox"/> |
| 27 | <input type="checkbox"/> | <input type="checkbox"/> |



**2116 H**

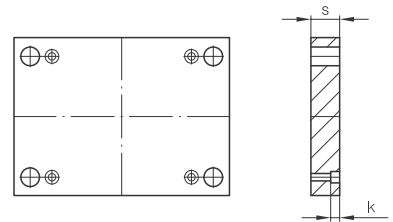

| S  | Material                 |                          |                          |
|----|--------------------------|--------------------------|--------------------------|
|    | 1.1730                   | 1.2162                   | 1.2312                   |
| 17 | <input type="checkbox"/> | <input type="checkbox"/> |                          |
| 22 | <input type="checkbox"/> |                          | <input type="checkbox"/> |
| 27 | <input type="checkbox"/> |                          | <input type="checkbox"/> |



2120 H

2125 H

## 246 x 296

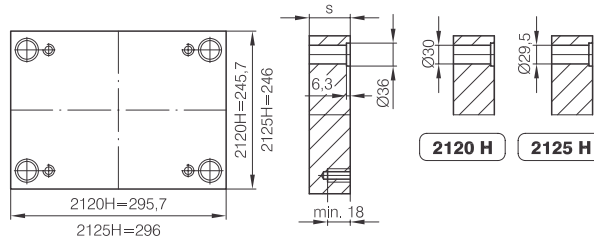

| S   | Material |        |        |        |        |        |        |        |
|-----|----------|--------|--------|--------|--------|--------|--------|--------|
|     | 1.1730   | 1.2162 | 1.2767 | 1.2083 | 1.2085 | 1.2311 | 1.2312 | 1.2343 |
| 17  | ■        | ■      | ■      |        | ■      | ■      | ■      |        |
| 22  | ■        | ■      | ■      |        | ■      | ■      | ■      |        |
| 27  | ■        | ■      | ■      |        | ■      | ■      | ■      |        |
| 36  | ■        | ■      | ■      | ■      | ■      | ■      | ■      | ■      |
| 46  | ■        | ■      | ■      | ■      | ■      | ■      | ■      | ■      |
| 56  | ■        | ■      | ■      | ■      | ■      | ■      | ■      | ■      |
| 66  | ■        | ■      | ■      | ■      | ■      | ■      | ■      | ■      |
| 76  | ■        | ■      | ■      | ■      | ■      | ■      | ■      | ■      |
| 86  | ■        | ■      | ■      | ■      | ■      | ■      | ■      | ■      |
| 96  | ■        | ■      | ■      | ■      | ■      | ■      | ■      | ■      |
| 116 | ■        | ■      | ■      | ■      | ■      | ■      | ■      | ■      |



2130 H



2140 H

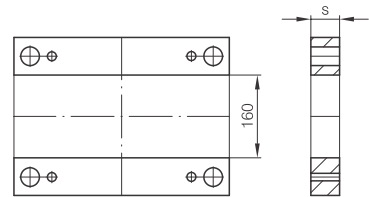
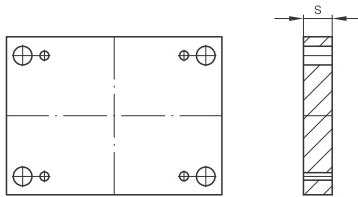

| S  | Material |        |
|----|----------|--------|
|    | 1.1730   | 1.2312 |
| 36 | ■        | ■      |

| S  | Material |        |
|----|----------|--------|
|    | 1.1730   | 1.2312 |
| 56 | ■        |        |
| 76 | ■        |        |
| 96 | ■        |        |



2160 H



2170 H

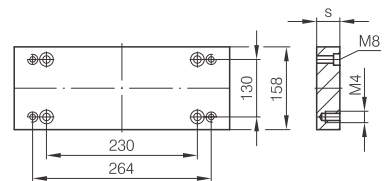
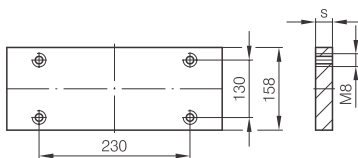

| S  | Material |        |
|----|----------|--------|
|    | 1.1730   | 1.2312 |
| 12 | ■        |        |

| S  | Material |        |
|----|----------|--------|
|    | 1.1730   | 1.2312 |
| 17 | ■        | ■      |

# 246 x 346

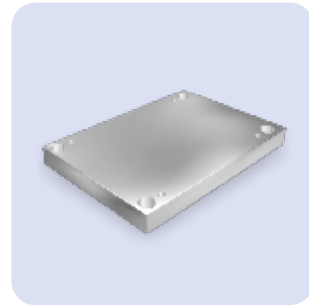
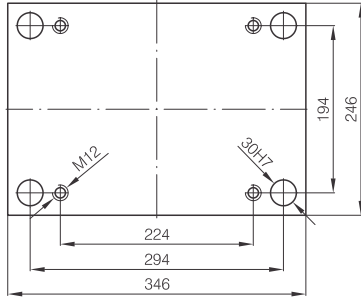

**2110 H**

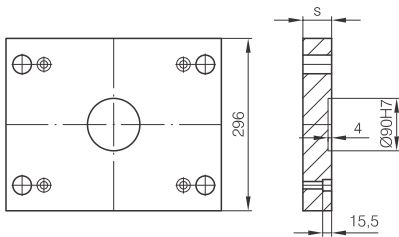

| S  | Material                 |                          |
|----|--------------------------|--------------------------|
|    | 1.1730                   | 1.2312                   |
| 27 | <input type="checkbox"/> | <input type="checkbox"/> |
| 36 | <input type="checkbox"/> | <input type="checkbox"/> |



**2111 H**

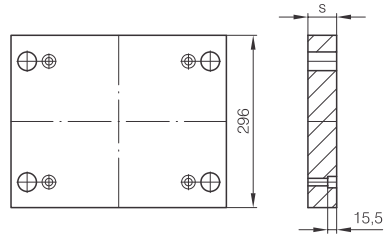

| S  | Material                 |                          |
|----|--------------------------|--------------------------|
|    | 1.1730                   | 1.2312                   |
| 27 | <input type="checkbox"/> | <input type="checkbox"/> |
| 36 | <input type="checkbox"/> | <input type="checkbox"/> |



**2115 H**

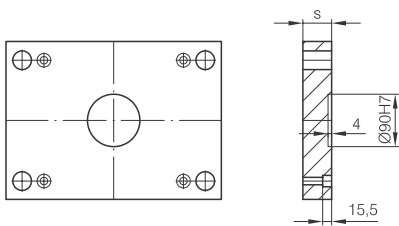

| S  | Material                 |                          |
|----|--------------------------|--------------------------|
|    | 1.1730                   | 1.2312                   |
| 22 | <input type="checkbox"/> | <input type="checkbox"/> |
| 27 | <input type="checkbox"/> | <input type="checkbox"/> |



**2116 H**

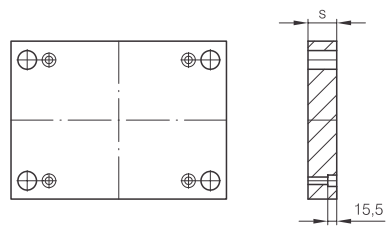

| S  | Material                 |                          |                          |
|----|--------------------------|--------------------------|--------------------------|
|    | 1.1730                   | 1.2162                   | 1.2312                   |
| 22 | <input type="checkbox"/> | <input type="checkbox"/> | <input type="checkbox"/> |
| 27 | <input type="checkbox"/> | <input type="checkbox"/> | <input type="checkbox"/> |



2120 H

2125 H

## 246 x 346

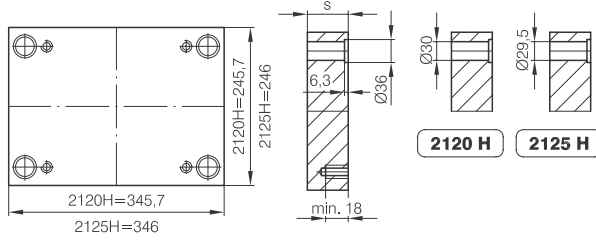

| S   | Material |        |        |        |        |        |        |        |
|-----|----------|--------|--------|--------|--------|--------|--------|--------|
|     | 1.1730   | 1.2162 | 1.2767 | 1.2083 | 1.2085 | 1.2311 | 1.2312 | 1.2343 |
| 22  | ■        | ■      | ■      |        | ■      | ■      | ■      |        |
| 27  | ■        | ■      | ■      |        | ■      | ■      | ■      |        |
| 36  | ■        | ■      | ■      | ■      | ■      | ■      | ■      | ■      |
| 46  | ■        | ■      | ■      | ■      | ■      | ■      | ■      | ■      |
| 56  | ■        | ■      | ■      | ■      | ■      | ■      | ■      | ■      |
| 66  | ■        | ■      | ■      | ■      | ■      | ■      | ■      | ■      |
| 76  | ■        | ■      | ■      | ■      | ■      | ■      | ■      | ■      |
| 86  | ■        | ■      | ■      | ■      | ■      | ■      | ■      | ■      |
| 96  | ■        | ■      | ■      | ■      | ■      | ■      | ■      | ■      |
| 116 | ■        | ■      | ■      | ■      | ■      | ■      | ■      | ■      |



2130 H



2140 H

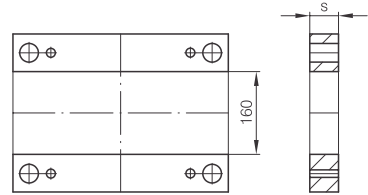
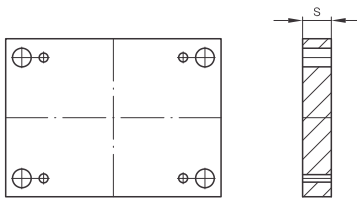

| S  | Material |        |
|----|----------|--------|
|    | 1.1730   | 1.2312 |
| 36 | ■        | ■      |
| 46 | ■        | ■      |

| S  | Material |        |
|----|----------|--------|
|    | 1.1730   | 1.2312 |
| 56 | ■        |        |
| 76 | ■        |        |
| 96 | ■        |        |



2160 H



2170 H

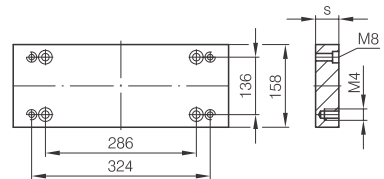
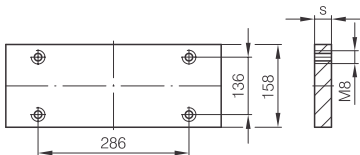

| S  | Material |        |
|----|----------|--------|
|    | 1.1730   | 1.2312 |
| 17 | ■        |        |

| S  | Material |        |
|----|----------|--------|
|    | 1.1730   | 1.2312 |
| 22 | ■        | ■      |

# 246 x 396

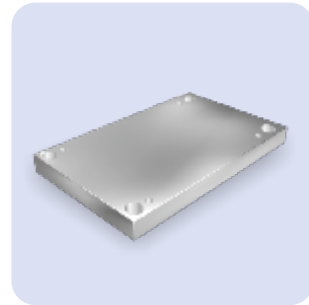
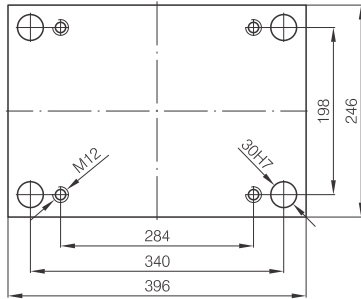

**2110 H**

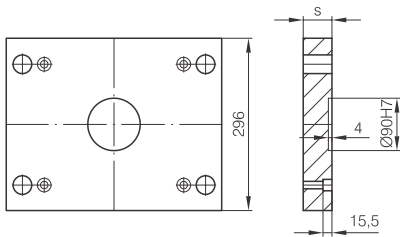

| S  | Material                 |                          |
|----|--------------------------|--------------------------|
|    | 1.1730                   | 1.2312                   |
| 27 | <input type="checkbox"/> | <input type="checkbox"/> |
| 36 | <input type="checkbox"/> | <input type="checkbox"/> |



**2111 H**

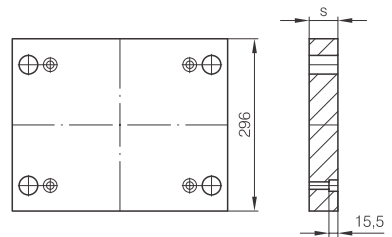

| S  | Material                 |                          |
|----|--------------------------|--------------------------|
|    | 1.1730                   | 1.2312                   |
| 27 | <input type="checkbox"/> | <input type="checkbox"/> |
| 36 | <input type="checkbox"/> | <input type="checkbox"/> |



**2115 H**

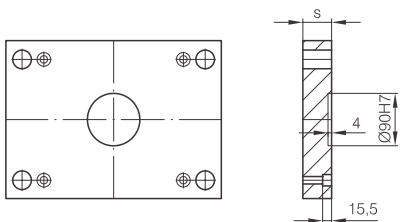

| S  | Material                 |                          |
|----|--------------------------|--------------------------|
|    | 1.1730                   | 1.2312                   |
| 22 | <input type="checkbox"/> | <input type="checkbox"/> |
| 27 | <input type="checkbox"/> | <input type="checkbox"/> |



**2116 H**

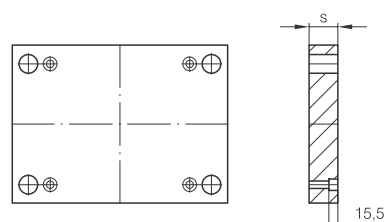

| S  | Material                 |                          |                          |
|----|--------------------------|--------------------------|--------------------------|
|    | 1.1730                   | 1.2162                   | 1.2312                   |
| 22 | <input type="checkbox"/> | <input type="checkbox"/> | <input type="checkbox"/> |
| 27 | <input type="checkbox"/> | <input type="checkbox"/> | <input type="checkbox"/> |



2120 H

2125 H

## 246 x 396

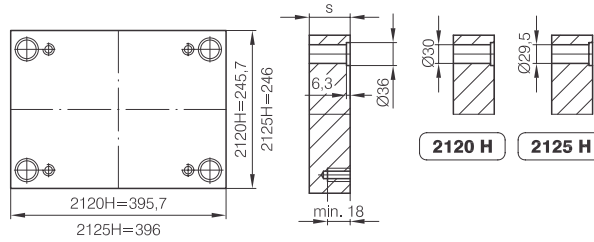

| S   | Material |        |        |        |        |        |        |        |
|-----|----------|--------|--------|--------|--------|--------|--------|--------|
|     | 1.1730   | 1.2162 | 1.2767 | 1.2083 | 1.2085 | 1.2311 | 1.2312 | 1.2343 |
| 22  | ■        | ■      | ■      |        | ■      | ■      | ■      |        |
| 27  | ■        | ■      | ■      |        | ■      | ■      | ■      |        |
| 36  | ■        | ■      | ■      | ■      | ■      | ■      | ■      | ■      |
| 46  | ■        | ■      | ■      | ■      | ■      | ■      | ■      | ■      |
| 56  | ■        | ■      | ■      | ■      | ■      | ■      | ■      | ■      |
| 66  | ■        | ■      | ■      | ■      | ■      | ■      | ■      | ■      |
| 76  | ■        | ■      | ■      | ■      | ■      | ■      | ■      | ■      |
| 86  | ■        | ■      | ■      | ■      | ■      | ■      | ■      | ■      |
| 96  | ■        | ■      | ■      | ■      | ■      | ■      | ■      | ■      |
| 116 | ■        | ■      | ■      | ■      | ■      | ■      | ■      | ■      |



2130 H



2140 H



| S  | Material |        |
|----|----------|--------|
|    | 1.1730   | 1.2312 |
| 36 | ■        | ■      |
| 46 | ■        | ■      |

| S  | Material |        |
|----|----------|--------|
|    | 1.1730   | 1.2312 |
| 56 | ■        |        |
| 76 | ■        |        |
| 96 | ■        |        |



2160 H



2170 H

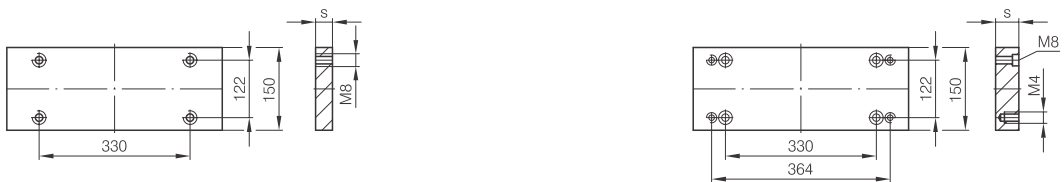

| S  | Material |        |
|----|----------|--------|
|    | 1.1730   | 1.2312 |
| 17 | ■        |        |

| S  | Material |        |
|----|----------|--------|
|    | 1.1730   | 1.2312 |
| 22 | ■        | ■      |

# 296 x 296

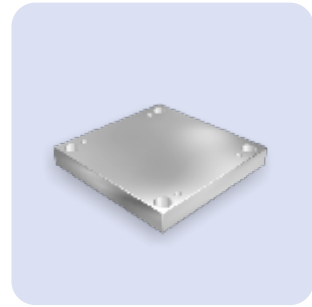
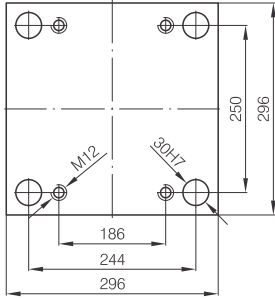

**2110 H**

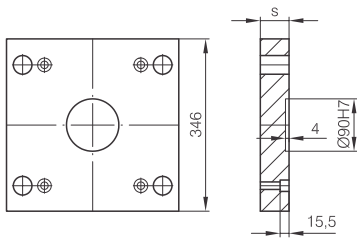

| S  | Material                 |                          |
|----|--------------------------|--------------------------|
|    | 1.1730                   | 1.2312                   |
| 27 | <input type="checkbox"/> | <input type="checkbox"/> |
| 36 | <input type="checkbox"/> | <input type="checkbox"/> |



**2111 H**

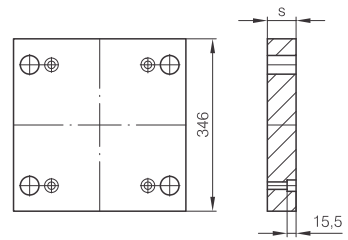

| S  | Material                 |                          |
|----|--------------------------|--------------------------|
|    | 1.1730                   | 1.2312                   |
| 27 | <input type="checkbox"/> | <input type="checkbox"/> |
| 36 | <input type="checkbox"/> | <input type="checkbox"/> |



**2115 H**

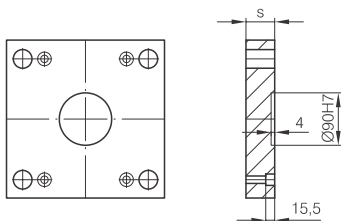

| S  | Material                 |                          |
|----|--------------------------|--------------------------|
|    | 1.1730                   | 1.2312                   |
| 22 | <input type="checkbox"/> | <input type="checkbox"/> |
| 27 | <input type="checkbox"/> | <input type="checkbox"/> |



**2116 H**

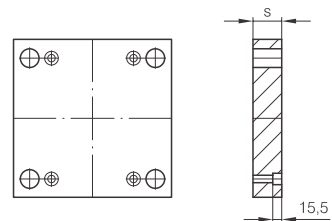

| S  | Material                 |                          |                          |
|----|--------------------------|--------------------------|--------------------------|
|    | 1.1730                   | 1.2162                   | 1.2312                   |
| 22 | <input type="checkbox"/> | <input type="checkbox"/> | <input type="checkbox"/> |
| 27 | <input type="checkbox"/> | <input type="checkbox"/> | <input type="checkbox"/> |



2120 H

2125 H

## 296 x 296

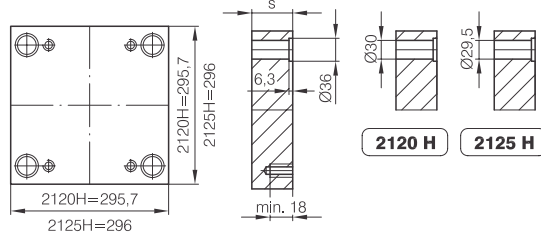

| S   | Material |        |        |        |        |        |        |        |
|-----|----------|--------|--------|--------|--------|--------|--------|--------|
|     | 1.1730   | 1.2162 | 1.2767 | 1.2083 | 1.2085 | 1.2311 | 1.2312 | 1.2343 |
| 22  | ■        | ■      | ■      |        | ■      | ■      | ■      |        |
| 27  | ■        | ■      | ■      |        | ■      | ■      | ■      |        |
| 36  | ■        | ■      | ■      |        | ■      | ■      | ■      |        |
| 46  | ■        | ■      | ■      | ■      | ■      | ■      | ■      | ■      |
| 56  | ■        | ■      | ■      | ■      | ■      | ■      | ■      | ■      |
| 66  | ■        | ■      | ■      | ■      | ■      | ■      | ■      | ■      |
| 76  | ■        | ■      | ■      | ■      | ■      | ■      | ■      | ■      |
| 86  | ■        | ■      | ■      | ■      | ■      | ■      | ■      | ■      |
| 96  | ■        | ■      | ■      | ■      | ■      | ■      | ■      | ■      |
| 116 | ■        | ■      | ■      | ■      | ■      | ■      | ■      | ■      |



2130 H



2140 H

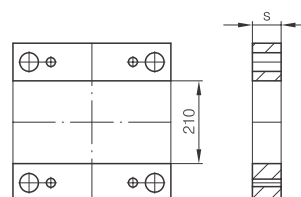
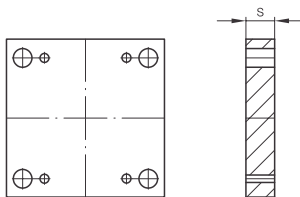

| S  | Material |        |
|----|----------|--------|
|    | 1.1730   | 1.2312 |
| 36 | ■        | ■      |
| 46 | ■        | ■      |

| S  | Material |        |
|----|----------|--------|
|    | 1.1730   | 1.2312 |
| 56 | ■        |        |
| 76 | ■        |        |
| 96 | ■        |        |



2160 H



2170 H

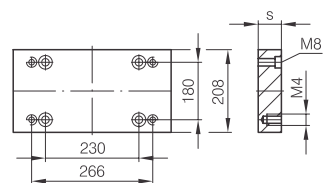
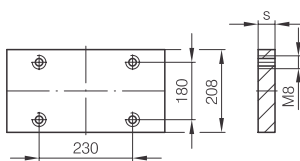

| S  | Material |        |
|----|----------|--------|
|    | 1.1730   | 1.2312 |
| 12 | ■        |        |

| S  | Material |        |
|----|----------|--------|
|    | 1.1730   | 1.2312 |
| 17 | ■        | ■      |

# 296 x 346

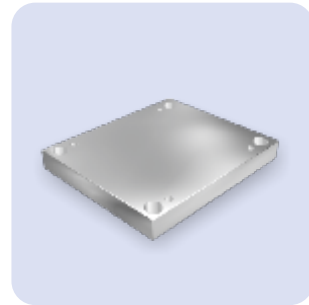
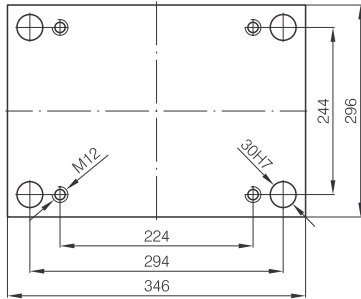

**2110 H**

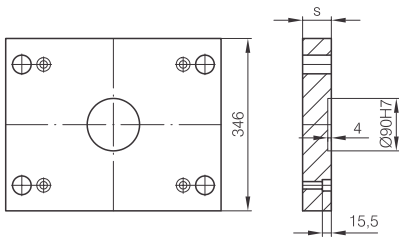

| S  | Material                 |                          |
|----|--------------------------|--------------------------|
|    | 1.1730                   | 1.2312                   |
| 27 | <input type="checkbox"/> | <input type="checkbox"/> |
| 36 | <input type="checkbox"/> | <input type="checkbox"/> |



**2111 H**

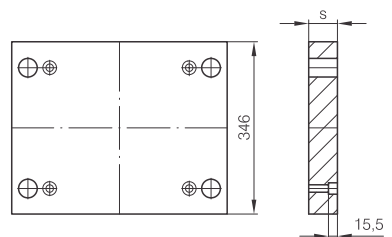

| S  | Material                 |                          |
|----|--------------------------|--------------------------|
|    | 1.1730                   | 1.2312                   |
| 27 | <input type="checkbox"/> | <input type="checkbox"/> |
| 36 | <input type="checkbox"/> | <input type="checkbox"/> |



**2115 H**

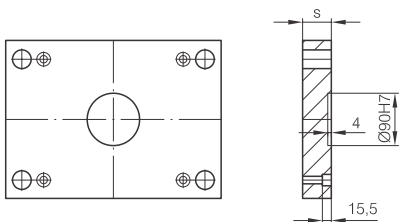

| S  | Material                 |                          |
|----|--------------------------|--------------------------|
|    | 1.1730                   | 1.2312                   |
| 22 | <input type="checkbox"/> | <input type="checkbox"/> |
| 27 | <input type="checkbox"/> | <input type="checkbox"/> |



**2116 H**

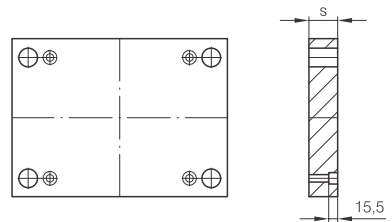

| S  | Material                 |                          |                          |
|----|--------------------------|--------------------------|--------------------------|
|    | 1.1730                   | 1.2162                   | 1.2312                   |
| 22 | <input type="checkbox"/> | <input type="checkbox"/> | <input type="checkbox"/> |
| 27 | <input type="checkbox"/> | <input type="checkbox"/> | <input type="checkbox"/> |



2120 H

2125 H

## 296 x 346

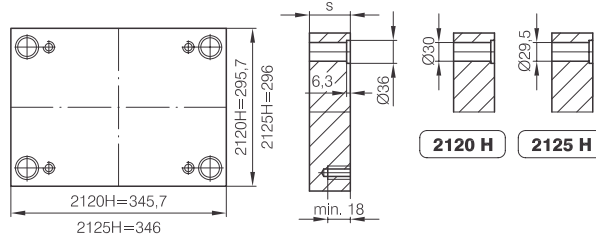

| S   | Material |        |        |        |        |        |        |        |
|-----|----------|--------|--------|--------|--------|--------|--------|--------|
|     | 1.1730   | 1.2162 | 1.2767 | 1.2083 | 1.2085 | 1.2311 | 1.2312 | 1.2343 |
| 22  | ■        | ■      | ■      |        | ■      | ■      | ■      |        |
| 27  | ■        | ■      | ■      |        | ■      | ■      | ■      |        |
| 36  | ■        | ■      | ■      | ■      | ■      | ■      | ■      | ■      |
| 46  | ■        | ■      | ■      | ■      | ■      | ■      | ■      | ■      |
| 56  | ■        | ■      | ■      | ■      | ■      | ■      | ■      | ■      |
| 66  | ■        | ■      | ■      | ■      | ■      | ■      | ■      | ■      |
| 76  | ■        | ■      | ■      | ■      | ■      | ■      | ■      | ■      |
| 86  | ■        | ■      | ■      | ■      | ■      | ■      | ■      | ■      |
| 96  | ■        | ■      | ■      | ■      | ■      | ■      | ■      | ■      |
| 116 | ■        | ■      | ■      | ■      | ■      | ■      | ■      | ■      |



2130 H



2140 H

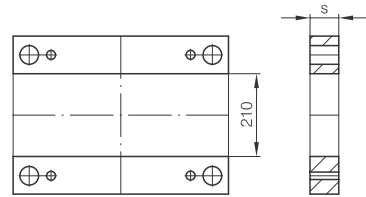
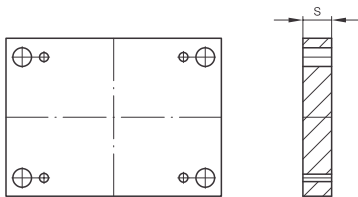

| S  | Material |        |
|----|----------|--------|
|    | 1.1730   | 1.2312 |
| 36 | ■        | ■      |
| 46 | ■        | ■      |

| S  | Material |        |
|----|----------|--------|
|    | 1.1730   | 1.2312 |
| 56 | ■        |        |
| 76 | ■        |        |
| 96 | ■        |        |



2160 H



2170 H

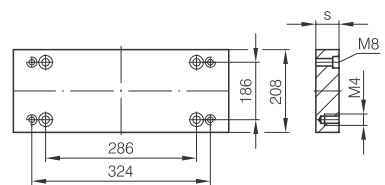
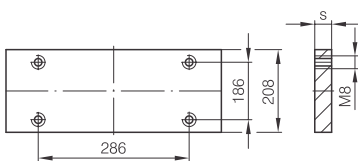

| S  | Material |        |
|----|----------|--------|
|    | 1.1730   | 1.2312 |
| 17 | ■        |        |

| S  | Material |        |
|----|----------|--------|
|    | 1.1730   | 1.2312 |
| 22 | ■        | ■      |

# 296 x 396

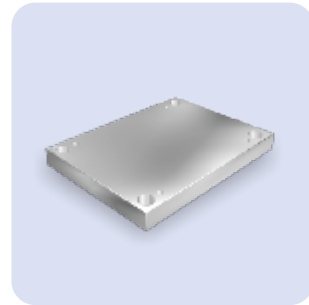
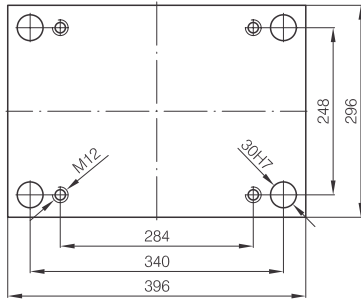

**2110 H**

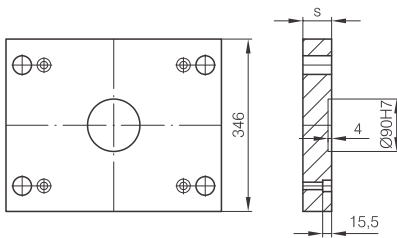

| S  | Material                 |                          |
|----|--------------------------|--------------------------|
|    | 1.1730                   | 1.2312                   |
| 27 | <input type="checkbox"/> | <input type="checkbox"/> |
| 36 | <input type="checkbox"/> | <input type="checkbox"/> |



**2111 H**

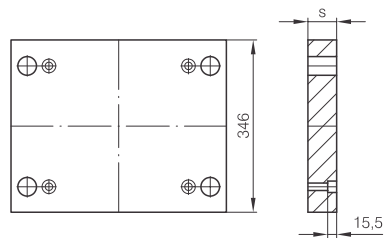

| S  | Material                 |                          |
|----|--------------------------|--------------------------|
|    | 1.1730                   | 1.2312                   |
| 27 | <input type="checkbox"/> | <input type="checkbox"/> |
| 36 | <input type="checkbox"/> | <input type="checkbox"/> |



**2115 H**

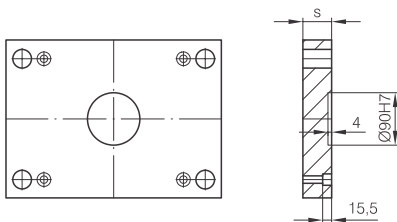

| S  | Material                 |                          |
|----|--------------------------|--------------------------|
|    | 1.1730                   | 1.2312                   |
| 22 | <input type="checkbox"/> | <input type="checkbox"/> |
| 27 | <input type="checkbox"/> | <input type="checkbox"/> |



**2116 H**

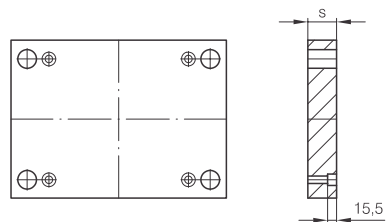

| S  | Material                 |                          |                          |
|----|--------------------------|--------------------------|--------------------------|
|    | 1.1730                   | 1.2162                   | 1.2312                   |
| 22 | <input type="checkbox"/> | <input type="checkbox"/> | <input type="checkbox"/> |
| 27 | <input type="checkbox"/> | <input type="checkbox"/> | <input type="checkbox"/> |



2120 H

2125 H

## 296 x 396

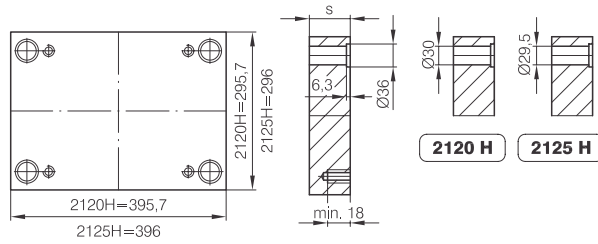

| S   | Material |        |        |        |        |        |        |        |
|-----|----------|--------|--------|--------|--------|--------|--------|--------|
|     | 1.1730   | 1.2162 | 1.2767 | 1.2083 | 1.2085 | 1.2311 | 1.2312 | 1.2343 |
| 22  | ■        | ■      | ■      |        | ■      | ■      | ■      |        |
| 27  | ■        | ■      | ■      |        | ■      | ■      | ■      |        |
| 36  | ■        | ■      | ■      | ■      | ■      | ■      | ■      | ■      |
| 46  | ■        | ■      | ■      | ■      | ■      | ■      | ■      | ■      |
| 56  | ■        | ■      | ■      | ■      | ■      | ■      | ■      | ■      |
| 66  | ■        | ■      | ■      | ■      | ■      | ■      | ■      | ■      |
| 76  | ■        | ■      | ■      | ■      | ■      | ■      | ■      | ■      |
| 86  | ■        | ■      | ■      | ■      | ■      | ■      | ■      | ■      |
| 96  | ■        | ■      | ■      | ■      | ■      | ■      | ■      | ■      |
| 116 | ■        | ■      | ■      | ■      | ■      | ■      | ■      | ■      |



2130 H

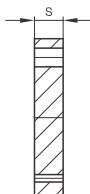
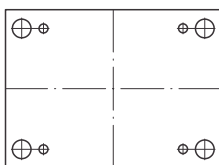

| S  | Material |        |
|----|----------|--------|
|    | 1.1730   | 1.2312 |
| 36 | ■        | ■      |
| 46 | ■        | ■      |



2140 H

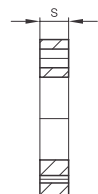
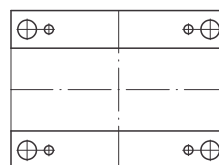

| S  | Material |        |
|----|----------|--------|
|    | 1.1730   | 1.2312 |
| 56 | ■        |        |
| 76 | ■        |        |
| 96 | ■        |        |



2160 H

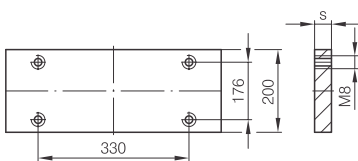

| S  | Material |        |
|----|----------|--------|
|    | 1.1730   | 1.2312 |
| 17 | ■        |        |



2170 H

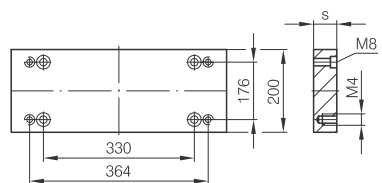

| S  | Material |        |
|----|----------|--------|
|    | 1.1730   | 1.2312 |
| 22 | ■        | ■      |

# 296 x 446

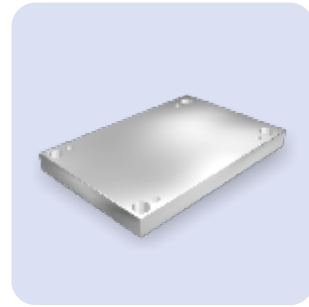
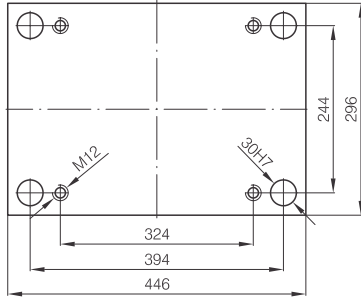

**2110 H**

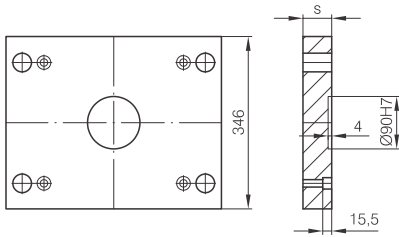

| S  | Material                 |                          |
|----|--------------------------|--------------------------|
|    | 1.1730                   | 1.2312                   |
| 36 | <input type="checkbox"/> | <input type="checkbox"/> |



**2111 H**

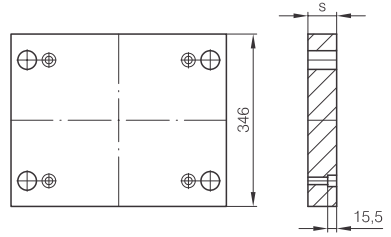

| S  | Material                 |                          |
|----|--------------------------|--------------------------|
|    | 1.1730                   | 1.2312                   |
| 36 | <input type="checkbox"/> | <input type="checkbox"/> |



**2115 H**

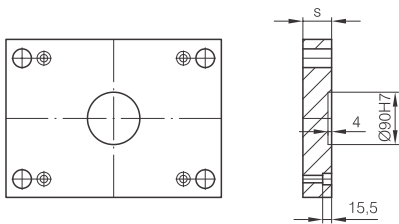

| S  | Material                 |                          |
|----|--------------------------|--------------------------|
|    | 1.1730                   | 1.2312                   |
| 27 | <input type="checkbox"/> | <input type="checkbox"/> |



**2116 H**

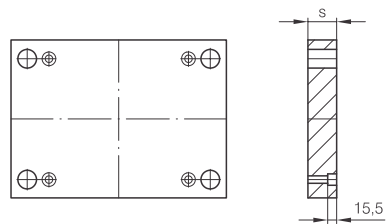

| S  | Material                 |                          |                          |
|----|--------------------------|--------------------------|--------------------------|
|    | 1.1730                   | 1.2162                   | 1.2312                   |
| 27 | <input type="checkbox"/> | <input type="checkbox"/> | <input type="checkbox"/> |



2120 H

2125 H

## 296 x 446

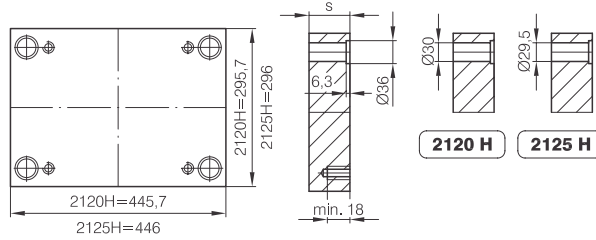

| S   | Material |        |        |        |        |        |        |        |
|-----|----------|--------|--------|--------|--------|--------|--------|--------|
|     | 1.1730   | 1.2162 | 1.2767 | 1.2083 | 1.2085 | 1.2311 | 1.2312 | 1.2343 |
| 27  | ■        | ■      |        |        | ■      | ■      | ■      |        |
| 36  | ■        | ■      |        |        | ■      | ■      | ■      |        |
| 46  | ■        | ■      |        |        | ■      | ■      | ■      |        |
| 56  | ■        | ■      |        |        | ■      | ■      | ■      |        |
| 66  | ■        | ■      |        |        | ■      | ■      | ■      |        |
| 76  | ■        | ■      |        |        | ■      | ■      | ■      |        |
| 86  | ■        | ■      |        |        | ■      | ■      | ■      |        |
| 96  | ■        | ■      |        |        | ■      | ■      | ■      |        |
| 116 | ■        | ■      |        |        | ■      | ■      | ■      |        |



2130 H



2140 H

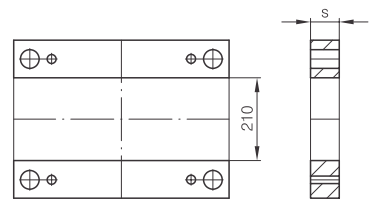
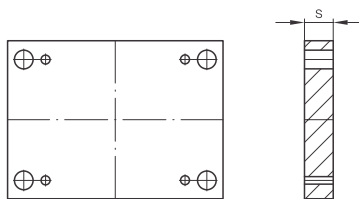

| S  | Material |        |
|----|----------|--------|
|    | 1.1730   | 1.2312 |
| 36 | ■        | ■      |
| 46 | ■        | ■      |

| S  | Material |        |
|----|----------|--------|
|    | 1.1730   | 1.2312 |
| 56 | ■        |        |
| 76 | ■        |        |
| 96 | ■        |        |



2160 H



2170 H

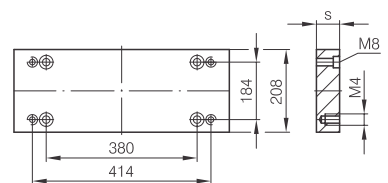
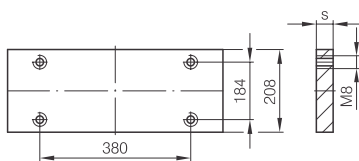

| S  | Material |        |
|----|----------|--------|
|    | 1.1730   | 1.2312 |
| 17 | ■        |        |

| S  | Material |        |
|----|----------|--------|
|    | 1.1730   | 1.2312 |
| 22 | ■        | ■      |

# 346 x 346

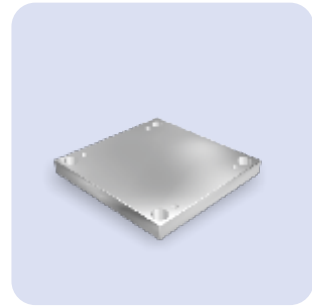
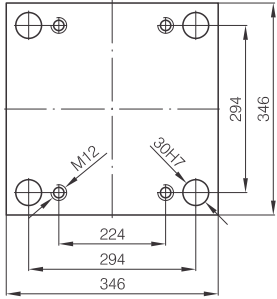

**2110 H**

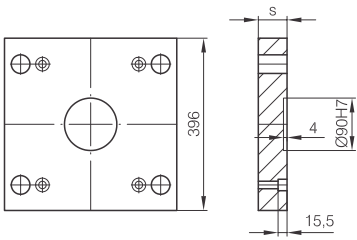

| S  | Material                 |                          |
|----|--------------------------|--------------------------|
|    | 1.1730                   | 1.2312                   |
| 27 | <input type="checkbox"/> | <input type="checkbox"/> |
| 36 | <input type="checkbox"/> | <input type="checkbox"/> |



**2111 H**

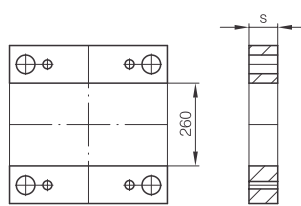

| S  | Material                 |                          |
|----|--------------------------|--------------------------|
|    | 1.1730                   | 1.2312                   |
| 27 | <input type="checkbox"/> | <input type="checkbox"/> |
| 36 | <input type="checkbox"/> | <input type="checkbox"/> |



**2115 H**

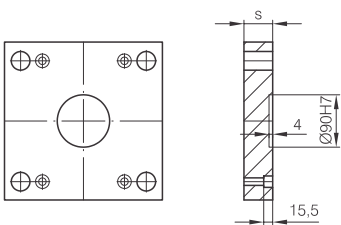

| S  | Material                 |                          |
|----|--------------------------|--------------------------|
|    | 1.1730                   | 1.2312                   |
| 22 | <input type="checkbox"/> | <input type="checkbox"/> |
| 27 | <input type="checkbox"/> | <input type="checkbox"/> |



**2116 H**

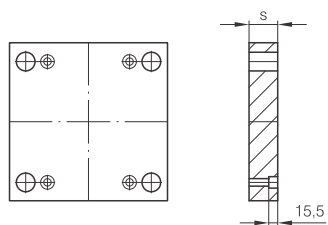

| S  | Material                 |                          |                          |
|----|--------------------------|--------------------------|--------------------------|
|    | 1.1730                   | 1.2162                   | 1.2312                   |
| 22 | <input type="checkbox"/> | <input type="checkbox"/> | <input type="checkbox"/> |
| 27 | <input type="checkbox"/> | <input type="checkbox"/> | <input type="checkbox"/> |



2120 H

2125 H

## 346 x 346

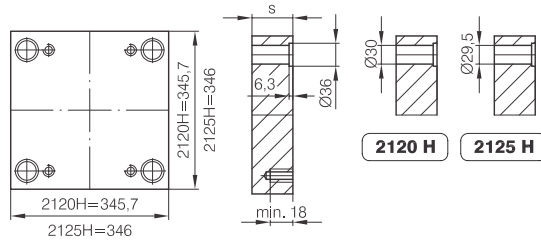

| S   | Material |        |        |        |        |        |        |        |
|-----|----------|--------|--------|--------|--------|--------|--------|--------|
|     | 1.1730   | 1.2162 | 1.2767 | 1.2083 | 1.2085 | 1.2311 | 1.2312 | 1.2343 |
| 22  | ■        | ■      | ■      |        | ■      | ■      | ■      |        |
| 27  | ■        | ■      | ■      |        | ■      | ■      | ■      |        |
| 36  | ■        | ■      | ■      | ■      | ■      | ■      | ■      | ■      |
| 46  | ■        | ■      | ■      | ■      | ■      | ■      | ■      | ■      |
| 56  | ■        | ■      | ■      | ■      | ■      | ■      | ■      | ■      |
| 66  | ■        | ■      | ■      | ■      | ■      | ■      | ■      | ■      |
| 76  | ■        | ■      | ■      | ■      | ■      | ■      | ■      | ■      |
| 86  | ■        | ■      | ■      | ■      | ■      | ■      | ■      | ■      |
| 96  | ■        | ■      | ■      | ■      | ■      | ■      | ■      | ■      |
| 116 | ■        | ■      | ■      | ■      | ■      | ■      | ■      | ■      |



2130 H



2140 H

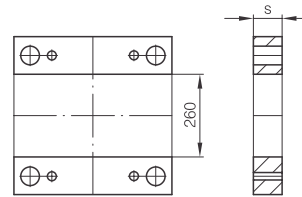
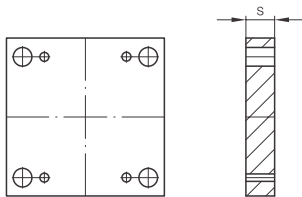

| S  | Material |        |
|----|----------|--------|
|    | 1.1730   | 1.2312 |
| 36 | ■        | ■      |
| 46 | ■        | ■      |

| S  | Material |        |
|----|----------|--------|
|    | 1.1730   | 1.2312 |
| 56 | ■        |        |
| 76 | ■        |        |
| 96 | ■        |        |



2160 H



2170 H

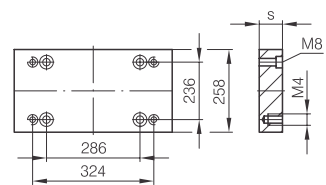
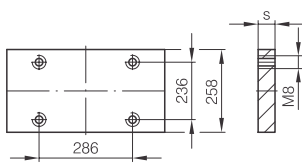

| S  | Material |        |
|----|----------|--------|
|    | 1.1730   | 1.2312 |
| 22 | ■        |        |

| S  | Material |        |
|----|----------|--------|
|    | 1.1730   | 1.2312 |
| 27 | ■        | ■      |

# 346 x 396

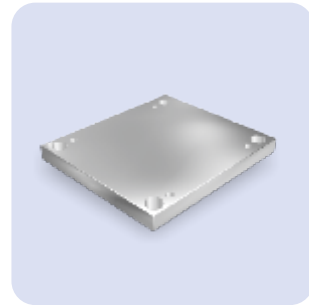
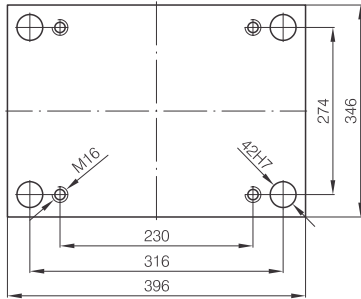

**2110 H**

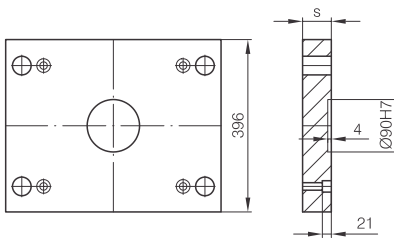

| S  | Material                            |                                     |
|----|-------------------------------------|-------------------------------------|
|    | 1.1730                              | 1.2312                              |
| 27 | <input checked="" type="checkbox"/> |                                     |
| 36 | <input checked="" type="checkbox"/> | <input checked="" type="checkbox"/> |
| 46 | <input checked="" type="checkbox"/> | <input checked="" type="checkbox"/> |



**2111 H**

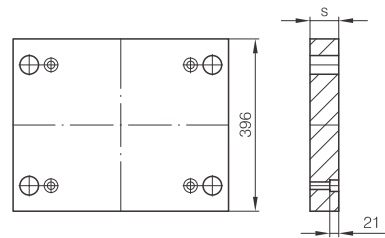

| S  | Material                            |                                     |
|----|-------------------------------------|-------------------------------------|
|    | 1.1730                              | 1.2312                              |
| 27 | <input checked="" type="checkbox"/> |                                     |
| 36 | <input checked="" type="checkbox"/> | <input checked="" type="checkbox"/> |
| 46 | <input checked="" type="checkbox"/> | <input checked="" type="checkbox"/> |



**2115 H**

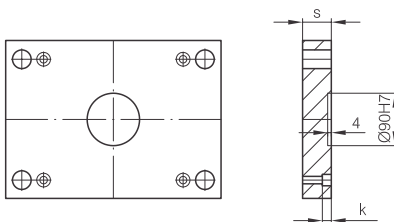

| S  | Material                            |                                     |
|----|-------------------------------------|-------------------------------------|
|    | 1.1730                              | 1.2312                              |
| 22 | <input checked="" type="checkbox"/> |                                     |
| 27 | <input checked="" type="checkbox"/> | <input checked="" type="checkbox"/> |
| 36 | <input checked="" type="checkbox"/> | <input checked="" type="checkbox"/> |



**2116 H**

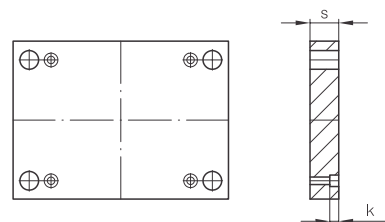

| S  | Material                            |                                     |                                     |
|----|-------------------------------------|-------------------------------------|-------------------------------------|
|    | 1.1730                              | 1.2162                              | 1.2312                              |
| 22 | <input checked="" type="checkbox"/> | <input checked="" type="checkbox"/> |                                     |
| 27 | <input checked="" type="checkbox"/> |                                     | <input checked="" type="checkbox"/> |
| 36 | <input checked="" type="checkbox"/> |                                     | <input checked="" type="checkbox"/> |



2120 H

2125 H

## 346 x 396

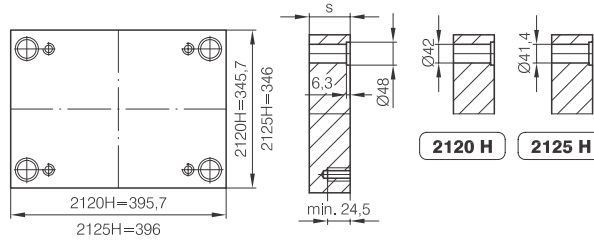

| S   | Material |        |        |        |        |        |        |        |
|-----|----------|--------|--------|--------|--------|--------|--------|--------|
|     | 1.1730   | 1.2162 | 1.2767 | 1.2083 | 1.2085 | 1.2311 | 1.2312 | 1.2343 |
| 22  |          | ■      |        |        |        |        |        |        |
| 27  | ■        | ■      | ■      |        | ■      | ■      | ■      |        |
| 36  | ■        | ■      | ■      |        | ■      | ■      | ■      |        |
| 46  | ■        | ■      | ■      | ■      | ■      | ■      | ■      | ■      |
| 56  | ■        | ■      | ■      | ■      | ■      | ■      | ■      | ■      |
| 66  | ■        |        |        |        | ■      |        | ■      |        |
| 76  | ■        | ■      | ■      | ■      | ■      | ■      | ■      | ■      |
| 86  | ■        |        |        |        | ■      |        | ■      |        |
| 96  | ■        | ■      | ■      | ■      | ■      | ■      | ■      | ■      |
| 116 |          | ■      | ■      | ■      | ■      | ■      | ■      | ■      |



2130 H



2140 H

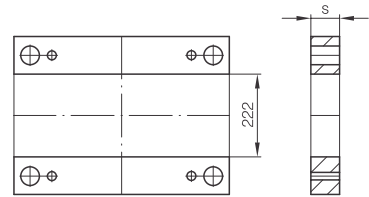
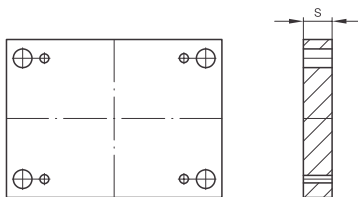

| S  | Material |        |
|----|----------|--------|
|    | 1.1730   | 1.2312 |
| 27 | ■        |        |
| 36 | ■        | ■      |
| 46 | ■        | ■      |

| S   | Material |        |
|-----|----------|--------|
|     | 1.1730   | 1.2312 |
| 56  | ■        |        |
| 66  | ■        |        |
| 76  | ■        |        |
| 86  | ■        |        |
| 96  | ■        |        |
| 116 | ■        |        |



2160 H



2170 H

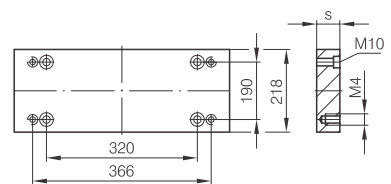
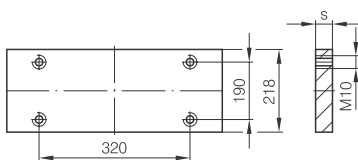

| S  | Material |        |
|----|----------|--------|
|    | 1.1730   | 1.2312 |
| 17 | ■        |        |

| S  | Material |        |
|----|----------|--------|
|    | 1.1730   | 1.2312 |
| 22 | ■        | ■      |

# 346 x 446

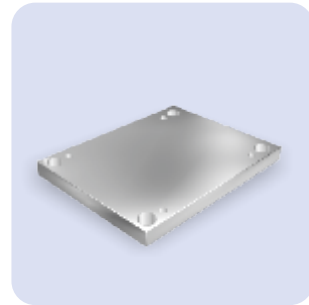
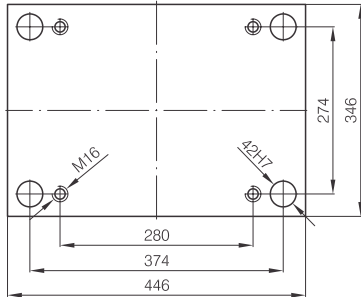

**2110 H**

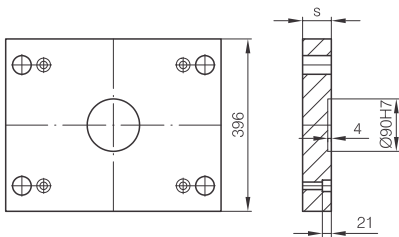

| S  | Material                            |                                     |
|----|-------------------------------------|-------------------------------------|
|    | 1.1730                              | 1.2312                              |
| 27 | <input checked="" type="checkbox"/> |                                     |
| 36 | <input checked="" type="checkbox"/> | <input checked="" type="checkbox"/> |
| 46 | <input checked="" type="checkbox"/> | <input checked="" type="checkbox"/> |



**2111 H**

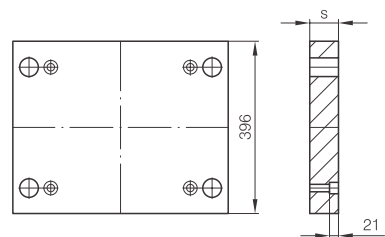

| S  | Material                            |                                     |
|----|-------------------------------------|-------------------------------------|
|    | 1.1730                              | 1.2312                              |
| 27 | <input checked="" type="checkbox"/> |                                     |
| 36 | <input checked="" type="checkbox"/> | <input checked="" type="checkbox"/> |
| 46 | <input checked="" type="checkbox"/> | <input checked="" type="checkbox"/> |



**2115 H**

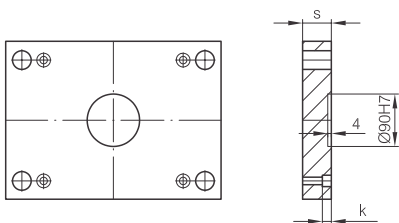

| S  | Material                            |                                     |
|----|-------------------------------------|-------------------------------------|
|    | 1.1730                              | 1.2312                              |
| 22 | <input checked="" type="checkbox"/> |                                     |
| 27 | <input checked="" type="checkbox"/> | <input checked="" type="checkbox"/> |
| 36 | <input checked="" type="checkbox"/> | <input checked="" type="checkbox"/> |



**2116 H**

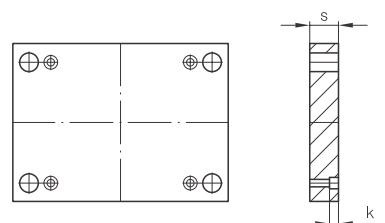

| S  | Material                            |        |                                     |
|----|-------------------------------------|--------|-------------------------------------|
|    | 1.1730                              | 1.2162 | 1.2312                              |
| 22 | <input checked="" type="checkbox"/> |        |                                     |
| 27 | <input checked="" type="checkbox"/> |        | <input checked="" type="checkbox"/> |
| 36 | <input checked="" type="checkbox"/> |        | <input checked="" type="checkbox"/> |



2120 H

2125 H

## 346 x 446

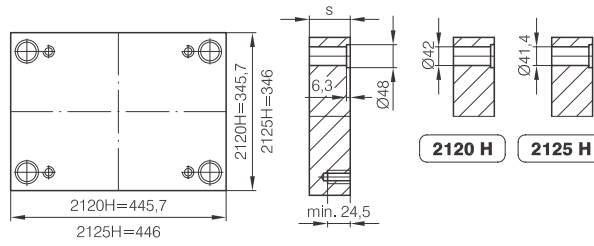

| S   | Material |        |        |        |        |        |        |        |
|-----|----------|--------|--------|--------|--------|--------|--------|--------|
|     | 1.1730   | 1.2162 | 1.2767 | 1.2083 | 1.2085 | 1.2311 | 1.2312 | 1.2343 |
| 27  | ■        |        |        |        | ■      |        | ■      |        |
| 36  | ■        | ■      |        |        | ■      | ■      | ■      |        |
| 46  | ■        | ■      |        |        | ■      | ■      | ■      |        |
| 56  | ■        | ■      |        | ■      | ■      | ■      | ■      | ■      |
| 66  | ■        | ■      |        |        | ■      | ■      | ■      |        |
| 76  | ■        | ■      |        | ■      | ■      | ■      | ■      | ■      |
| 86  | ■        | ■      |        |        | ■      | ■      | ■      |        |
| 96  | ■        | ■      |        | ■      | ■      | ■      | ■      | ■      |
| 116 | ■        | ■      |        | ■      | ■      | ■      | ■      | ■      |



2130 H



2140 H

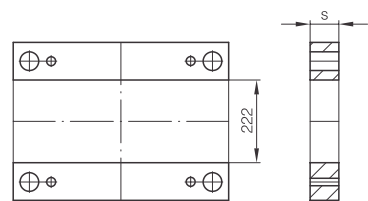
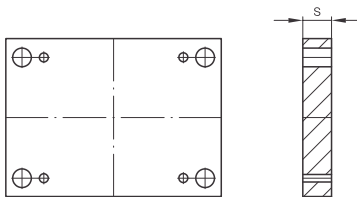

| S  | Material |        |
|----|----------|--------|
|    | 1.1730   | 1.2312 |
| 27 | ■        |        |
| 36 | ■        | ■      |
| 46 | ■        | ■      |

| S   | Material |        |
|-----|----------|--------|
|     | 1.1730   | 1.2312 |
| 56  | ■        |        |
| 66  | ■        |        |
| 76  | ■        |        |
| 86  | ■        |        |
| 96  | ■        |        |
| 116 | ■        |        |
| 136 | ■        |        |



2160 H



2170 H

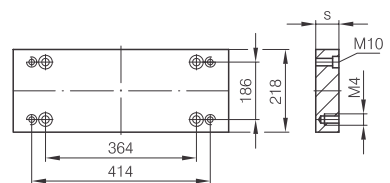
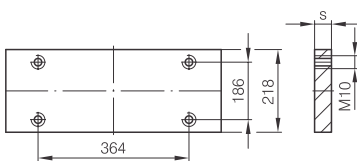

| S  | Material |        |
|----|----------|--------|
|    | 1.1730   | 1.2312 |
| 17 | ■        |        |

| S  | Material |        |
|----|----------|--------|
|    | 1.1730   | 1.2312 |
| 22 | ■        | ■      |

# 346 x 496

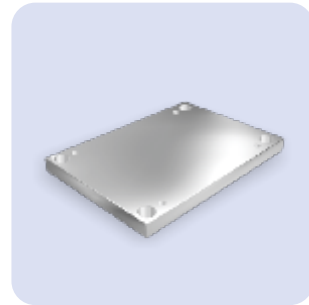
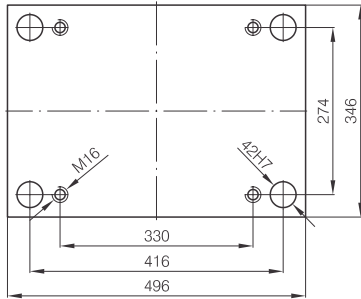

**2110 H**

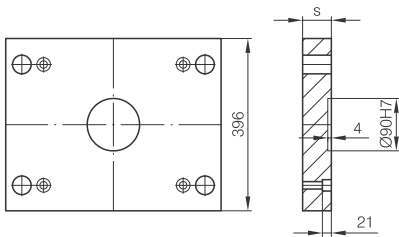

| S  | Material |        |
|----|----------|--------|
|    | 1.1730   | 1.2312 |
| 27 | ■        |        |
| 36 | ■        | ■      |
| 46 | ■        | ■      |



**2111 H**

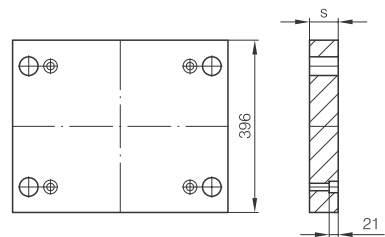

| S  | Material |        |
|----|----------|--------|
|    | 1.1730   | 1.2312 |
| 27 | ■        |        |
| 36 | ■        | ■      |
| 46 | ■        | ■      |



**2115 H**

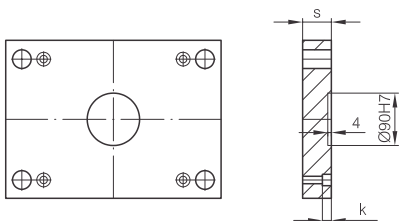

| S  | Material |        |
|----|----------|--------|
|    | 1.1730   | 1.2312 |
| 22 | ■        |        |
| 27 | ■        | ■      |
| 36 | ■        | ■      |



**2116 H**

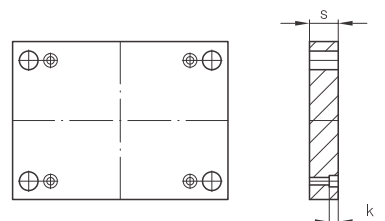

| S  | Material |        |        |
|----|----------|--------|--------|
|    | 1.1730   | 1.2162 | 1.2312 |
| 22 | ■        | ■      |        |
| 27 | ■        |        | ■      |
| 36 | ■        |        | ■      |



2120 H

2125 H

# 346 x 496

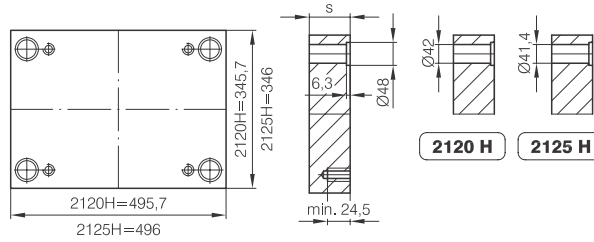

| S   | Material |        |        |        |        |        |        |        |
|-----|----------|--------|--------|--------|--------|--------|--------|--------|
|     | 1.1730   | 1.2162 | 1.2767 | 1.2083 | 1.2085 | 1.2311 | 1.2312 | 1.2343 |
| 22  |          | ■      |        |        |        |        |        |        |
| 27  | ■        | ■      | ■      |        | ■      | ■      | ■      |        |
| 36  | ■        | ■      | ■      |        | ■      | ■      | ■      |        |
| 46  | ■        | ■      | ■      | ■      | ■      | ■      | ■      | ■      |
| 56  | ■        | ■      | ■      | ■      | ■      | ■      | ■      | ■      |
| 66  | ■        |        |        |        | ■      |        | ■      |        |
| 76  | ■        | ■      | ■      | ■      | ■      | ■      | ■      | ■      |
| 86  | ■        |        |        |        | ■      |        | ■      |        |
| 96  | ■        | ■      | ■      | ■      | ■      | ■      | ■      | ■      |
| 116 | ■        | ■      | ■      | ■      | ■      | ■      | ■      | ■      |



2130 H



2140 H

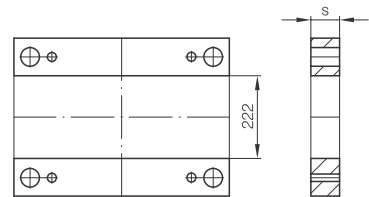
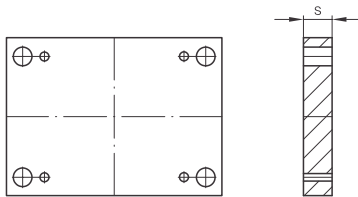

| S  | Material |        |
|----|----------|--------|
|    | 1.1730   | 1.2312 |
| 36 | ■        | ■      |
| 46 | ■        | ■      |

| S   | Material |        |
|-----|----------|--------|
|     | 1.1730   | 1.2312 |
| 56  | ■        |        |
| 66  | ■        |        |
| 76  | ■        |        |
| 86  | ■        |        |
| 96  | ■        |        |
| 116 | ■        |        |
| 136 | ■        |        |



2160 H



2170 H

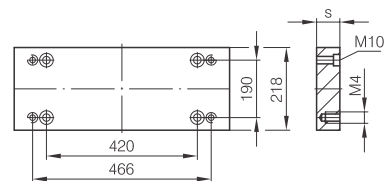
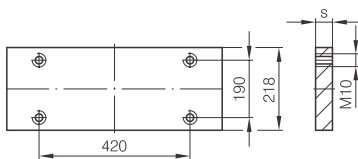

| S  | Material |        |
|----|----------|--------|
|    | 1.1730   | 1.2312 |
| 17 | ■        |        |

| S  | Material |        |
|----|----------|--------|
|    | 1.1730   | 1.2312 |
| 22 | ■        | ■      |

# 346 x 546

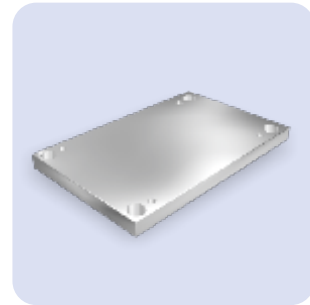
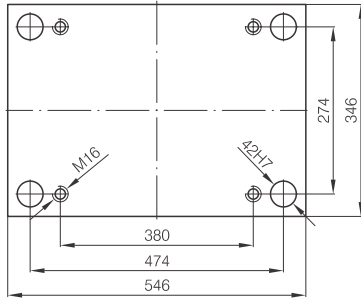

**2110 H**

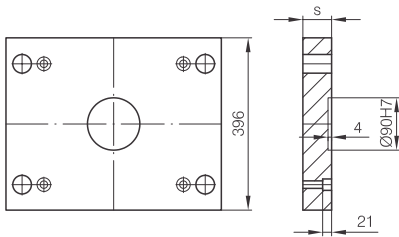

| S  | Material |        |
|----|----------|--------|
|    | 1.1730   | 1.2312 |
| 36 | ■        | ■      |
| 46 | ■        | ■      |



**2111 H**

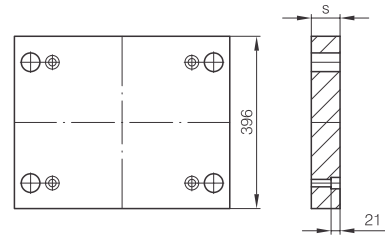

| S  | Material |        |
|----|----------|--------|
|    | 1.1730   | 1.2312 |
| 36 | ■        | ■      |
| 46 | ■        | ■      |



**2115 H**

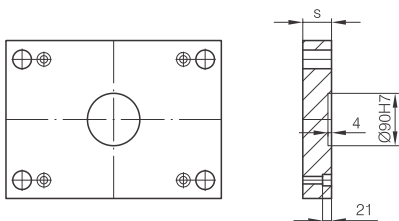

| S  | Material |        |
|----|----------|--------|
|    | 1.1730   | 1.2312 |
| 27 | ■        | ■      |
| 36 | ■        | ■      |



**2116 H**

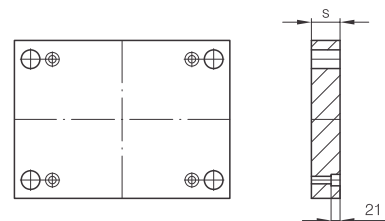

| S  | Material |        |        |
|----|----------|--------|--------|
|    | 1.1730   | 1.2162 | 1.2312 |
| 27 | ■        |        | ■      |
| 36 | ■        |        | ■      |



2120 H

2125 H

## 346 x 546

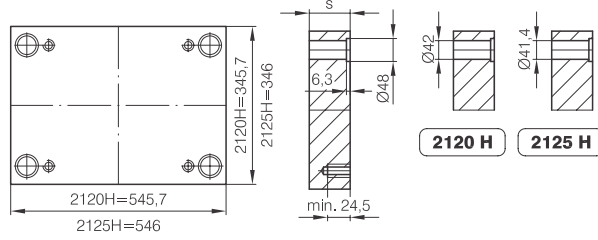

| S   | Material |        |        |        |        |        |        |        |
|-----|----------|--------|--------|--------|--------|--------|--------|--------|
|     | 1.1730   | 1.2162 | 1.2767 | 1.2083 | 1.2085 | 1.2311 | 1.2312 | 1.2343 |
| 27  | ■        |        |        |        | ■      |        | ■      |        |
| 36  | ■        | ■      |        |        | ■      | ■      | ■      |        |
| 46  | ■        | ■      |        |        | ■      | ■      | ■      |        |
| 56  | ■        | ■      |        |        | ■      | ■      | ■      | ■      |
| 66  | ■        |        |        |        | ■      |        | ■      |        |
| 76  | ■        | ■      |        |        | ■      | ■      | ■      | ■      |
| 86  | ■        |        |        |        | ■      |        | ■      |        |
| 96  | ■        | ■      |        |        | ■      | ■      | ■      | ■      |
| 116 | ■        | ■      |        |        | ■      | ■      | ■      | ■      |
| 136 | ■        | ■      |        |        | ■      | ■      | ■      | ■      |



2130 H



2140 H

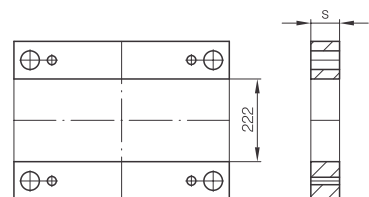
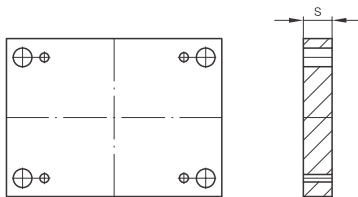

| S  | Material |        |
|----|----------|--------|
|    | 1.1730   | 1.2312 |
| 36 | ■        |        |
| 46 | ■        | ■      |

| S   | Material |        |
|-----|----------|--------|
|     | 1.1730   | 1.2312 |
| 66  | ■        |        |
| 76  | ■        |        |
| 86  | ■        |        |
| 96  | ■        |        |
| 116 | ■        |        |
| 136 | ■        |        |



2160 H



2170 H

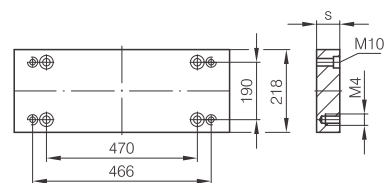
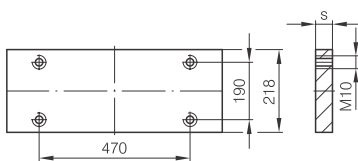

| S  | Material |        |
|----|----------|--------|
|    | 1.1730   | 1.2312 |
| 22 | ■        |        |

| S  | Material |        |
|----|----------|--------|
|    | 1.1730   | 1.2312 |
| 27 | ■        | ■      |

# 396 x 396

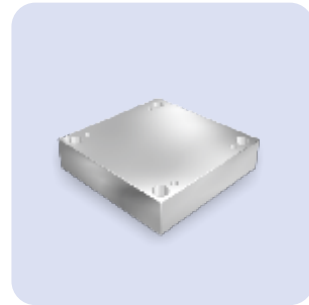
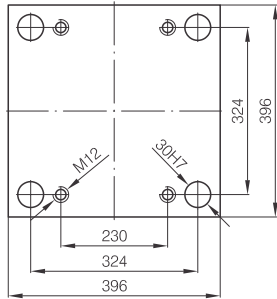

**2110 H**

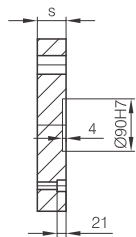
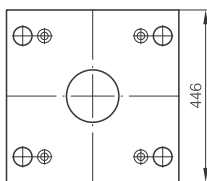

| S  | Material |        |
|----|----------|--------|
|    | 1.1730   | 1.2312 |
| 27 | ■        |        |
| 36 | ■        | ■      |
| 46 | ■        | ■      |



**2111 H**

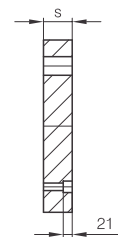
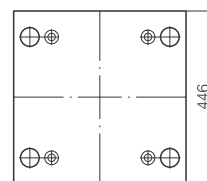

| S  | Material |        |
|----|----------|--------|
|    | 1.1730   | 1.2312 |
| 27 | ■        |        |
| 36 | ■        | ■      |
| 46 | ■        | ■      |



**2115 H**

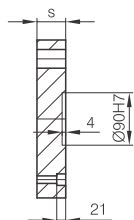

| S  | Material |        |
|----|----------|--------|
|    | 1.1730   | 1.2312 |
| 22 | ■        |        |
| 27 | ■        | ■      |
| 36 | ■        | ■      |



**2116 H**

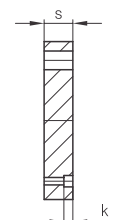
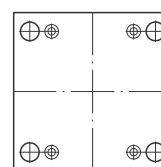

| S  | Material |        |        |
|----|----------|--------|--------|
|    | 1.1730   | 1.2162 | 1.2312 |
| 22 | ■        | ■      |        |
| 27 | ■        |        | ■      |
| 36 | ■        |        | ■      |



2120 H

2125 H

## 396 x 396

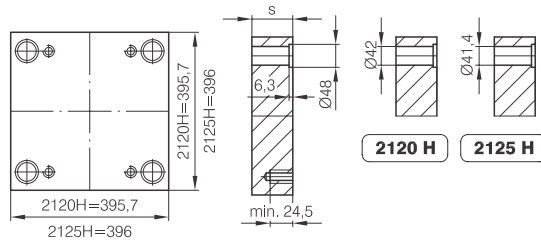

| S   | Material |        |        |        |        |        |        |        |
|-----|----------|--------|--------|--------|--------|--------|--------|--------|
|     | 1.1730   | 1.2162 | 1.2767 | 1.2083 | 1.2085 | 1.2311 | 1.2312 | 1.2343 |
| 22  |          | ■      |        |        |        |        |        |        |
| 27  | ■        | ■      | ■      |        | ■      | ■      | ■      |        |
| 36  | ■        | ■      | ■      |        | ■      | ■      | ■      |        |
| 46  | ■        | ■      | ■      |        | ■      | ■      | ■      |        |
| 56  | ■        | ■      | ■      |        | ■      | ■      | ■      | ■      |
| 66  | ■        |        |        |        | ■      |        | ■      |        |
| 76  | ■        | ■      | ■      |        | ■      | ■      | ■      | ■      |
| 86  | ■        |        |        |        | ■      |        | ■      |        |
| 96  | ■        | ■      | ■      |        | ■      | ■      | ■      | ■      |
| 116 | ■        | ■      | ■      |        | ■      | ■      | ■      | ■      |



2130 H



2140 H

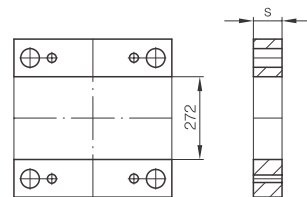
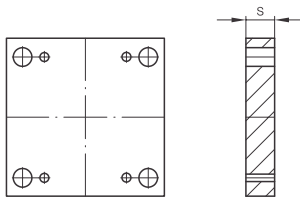

| S  | Material |        |
|----|----------|--------|
|    | 1.1730   | 1.2312 |
| 36 | ■        | ■      |
| 46 | ■        | ■      |

| S   | Material |        |
|-----|----------|--------|
|     | 1.1730   | 1.2312 |
| 56  | ■        |        |
| 66  | ■        |        |
| 76  | ■        |        |
| 86  | ■        |        |
| 96  | ■        |        |
| 116 | ■        |        |



2160 H



2170 H

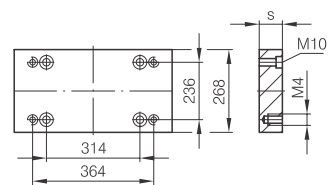
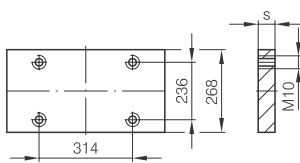

| S  | Material |        |
|----|----------|--------|
|    | 1.1730   | 1.2312 |
| 17 | ■        |        |

| S  | Material |        |
|----|----------|--------|
|    | 1.1730   | 1.2312 |
| 22 | ■        | ■      |

# 396 x 446

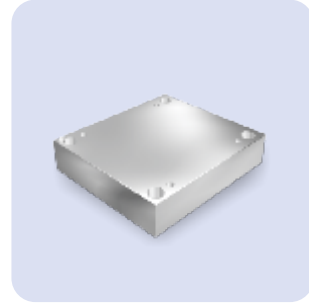
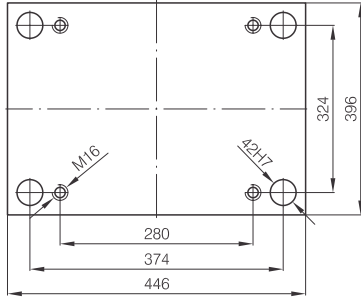

**2110 H**

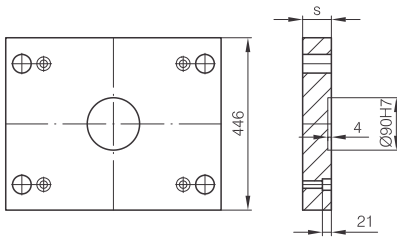

| S  | Material                 |                          |
|----|--------------------------|--------------------------|
|    | 1.1730                   | 1.2312                   |
| 27 | <input type="checkbox"/> | <input type="checkbox"/> |
| 36 | <input type="checkbox"/> | <input type="checkbox"/> |
| 46 | <input type="checkbox"/> | <input type="checkbox"/> |



**2111 H**

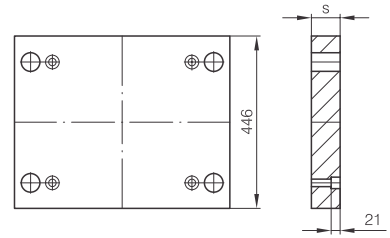

| S  | Material                 |                          |
|----|--------------------------|--------------------------|
|    | 1.1730                   | 1.2312                   |
| 27 | <input type="checkbox"/> | <input type="checkbox"/> |
| 36 | <input type="checkbox"/> | <input type="checkbox"/> |
| 46 | <input type="checkbox"/> | <input type="checkbox"/> |



**2115 H**

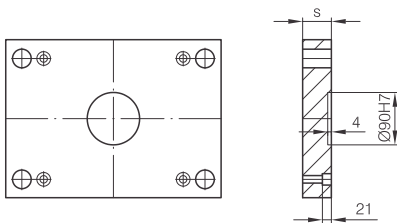

| S  | Material                 |                          |
|----|--------------------------|--------------------------|
|    | 1.1730                   | 1.2312                   |
| 27 | <input type="checkbox"/> | <input type="checkbox"/> |
| 36 | <input type="checkbox"/> | <input type="checkbox"/> |



**2116 H**

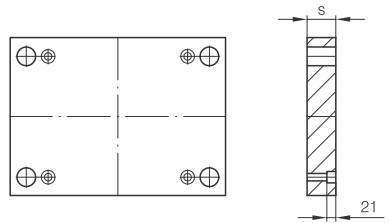

| S  | Material                 |                          |                          |
|----|--------------------------|--------------------------|--------------------------|
|    | 1.1730                   | 1.2162                   | 1.2312                   |
| 27 | <input type="checkbox"/> | <input type="checkbox"/> | <input type="checkbox"/> |
| 36 | <input type="checkbox"/> | <input type="checkbox"/> | <input type="checkbox"/> |



2120 H

2125 H

## 396 x 446

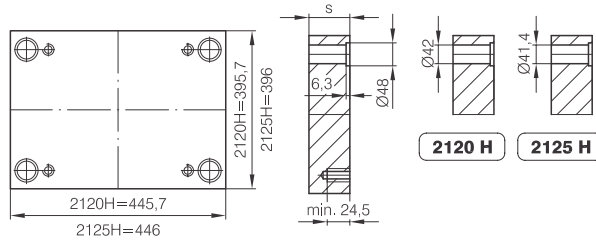

| S   | Material |        |        |        |        |        |        |        |
|-----|----------|--------|--------|--------|--------|--------|--------|--------|
|     | 1.1730   | 1.2162 | 1.2767 | 1.2083 | 1.2085 | 1.2311 | 1.2312 | 1.2343 |
| 27  | ■        |        |        |        | ■      |        | ■      |        |
| 36  | ■        | ■      |        |        | ■      | ■      | ■      |        |
| 46  | ■        | ■      |        |        | ■      | ■      | ■      |        |
| 56  | ■        | ■      |        |        | ■      | ■      | ■      | ■      |
| 66  | ■        |        |        |        | ■      | ■      | ■      |        |
| 76  | ■        | ■      |        |        | ■      | ■      | ■      | ■      |
| 86  | ■        |        |        |        | ■      | ■      | ■      |        |
| 96  | ■        | ■      |        |        | ■      | ■      | ■      | ■      |
| 116 | ■        | ■      |        |        | ■      | ■      | ■      | ■      |



2130 H



2140 H

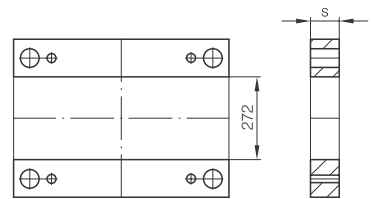
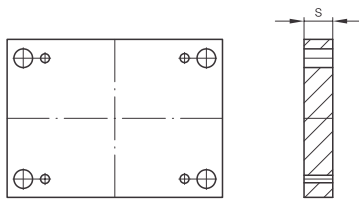

| S  | Material |        |
|----|----------|--------|
|    | 1.1730   | 1.2312 |
| 36 | ■        |        |
| 46 | ■        | ■      |

| S   | Material |        |
|-----|----------|--------|
|     | 1.1730   | 1.2312 |
| 56  | ■        |        |
| 66  | ■        |        |
| 76  | ■        |        |
| 86  | ■        |        |
| 96  | ■        |        |
| 116 | ■        |        |



2160 H



2170 H

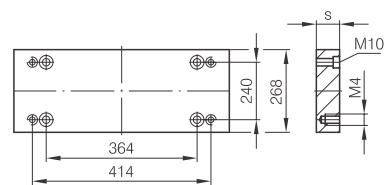
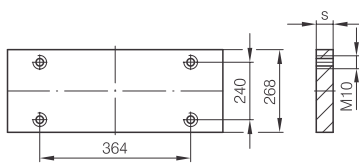

| S  | Material |        |
|----|----------|--------|
|    | 1.1730   | 1.2312 |
| 17 | ■        |        |

| S  | Material |        |
|----|----------|--------|
|    | 1.1730   | 1.2312 |
| 22 | ■        | ■      |

# 396 x 496

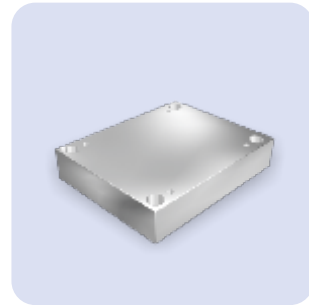
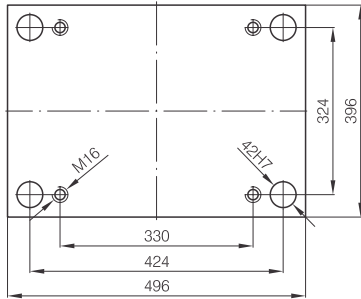

**2110 H**

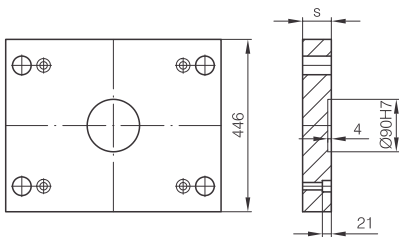

| S  | Material                 |                          |
|----|--------------------------|--------------------------|
|    | 1.1730                   | 1.2312                   |
| 36 | <input type="checkbox"/> | <input type="checkbox"/> |
| 46 | <input type="checkbox"/> | <input type="checkbox"/> |



**2111 H**

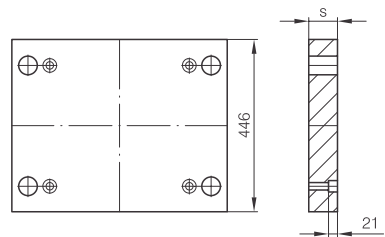

| S  | Material                 |                          |
|----|--------------------------|--------------------------|
|    | 1.1730                   | 1.2312                   |
| 36 | <input type="checkbox"/> | <input type="checkbox"/> |
| 46 | <input type="checkbox"/> | <input type="checkbox"/> |



**2115 H**

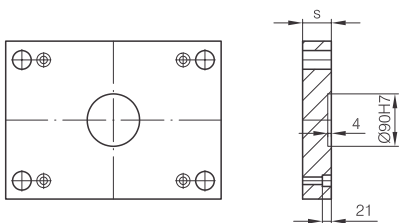

| S  | Material                 |                          |
|----|--------------------------|--------------------------|
|    | 1.1730                   | 1.2312                   |
| 27 | <input type="checkbox"/> | <input type="checkbox"/> |
| 36 | <input type="checkbox"/> | <input type="checkbox"/> |



**2116 H**

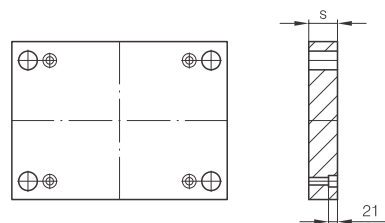

| S  | Material                 |                          |                          |
|----|--------------------------|--------------------------|--------------------------|
|    | 1.1730                   | 1.2162                   | 1.2312                   |
| 27 | <input type="checkbox"/> | <input type="checkbox"/> | <input type="checkbox"/> |
| 36 | <input type="checkbox"/> | <input type="checkbox"/> | <input type="checkbox"/> |



2120 H

2125 H

## 396 x 496

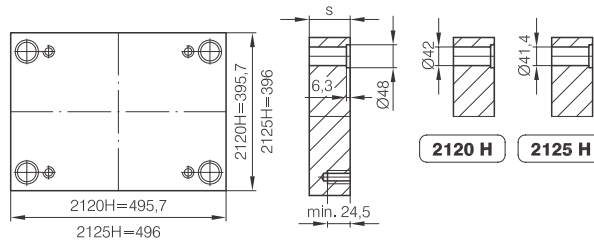

| S   | Material |        |        |        |        |        |        |        |
|-----|----------|--------|--------|--------|--------|--------|--------|--------|
|     | 1.1730   | 1.2162 | 1.2767 | 1.2083 | 1.2085 | 1.2311 | 1.2312 | 1.2343 |
| 27  | ■        |        |        |        | ■      |        | ■      |        |
| 36  | ■        | ■      |        |        | ■      | ■      | ■      |        |
| 46  | ■        | ■      |        |        | ■      | ■      | ■      |        |
| 56  | ■        | ■      |        |        | ■      | ■      |        | ■      |
| 66  | ■        |        |        |        | ■      |        | ■      |        |
| 76  | ■        | ■      |        |        | ■      | ■      | ■      | ■      |
| 86  | ■        |        |        |        | ■      |        | ■      |        |
| 96  | ■        | ■      |        |        | ■      | ■      | ■      | ■      |
| 116 | ■        | ■      |        |        | ■      | ■      | ■      | ■      |
| 136 | ■        | ■      |        |        | ■      | ■      | ■      | ■      |



2130 H



2140 H

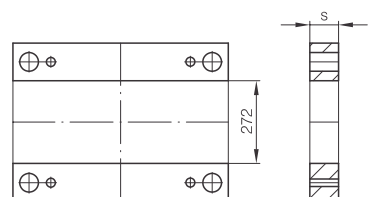
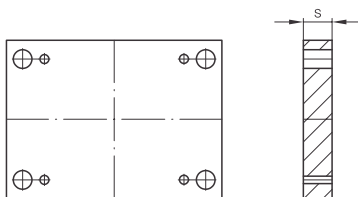

| S  | Material |        |
|----|----------|--------|
|    | 1.1730   | 1.2312 |
| 36 | ■        |        |
| 46 | ■        | ■      |

| S   | Material |        |
|-----|----------|--------|
|     | 1.1730   | 1.2312 |
| 66  | ■        |        |
| 76  | ■        |        |
| 86  | ■        |        |
| 96  | ■        |        |
| 116 | ■        |        |
| 136 | ■        |        |



2160 H



2170 H

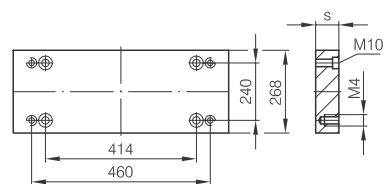
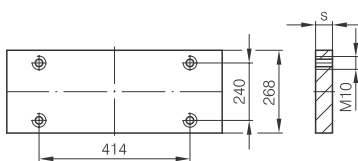

| S  | Material |        |
|----|----------|--------|
|    | 1.1730   | 1.2312 |
| 22 | ■        |        |

| S  | Material |        |
|----|----------|--------|
|    | 1.1730   | 1.2312 |
| 27 | ■        | ■      |

# 396 x 546

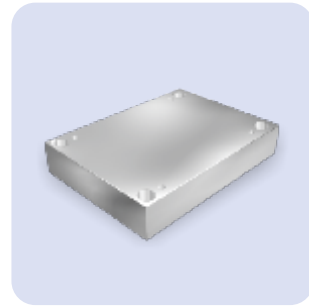
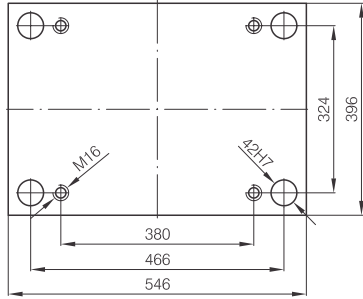

**2110 H**

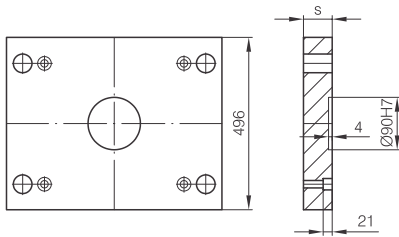

| S  | Material                 |                          |
|----|--------------------------|--------------------------|
|    | 1.1730                   | 1.2312                   |
| 36 | <input type="checkbox"/> | <input type="checkbox"/> |
| 46 | <input type="checkbox"/> | <input type="checkbox"/> |



**2111 H**

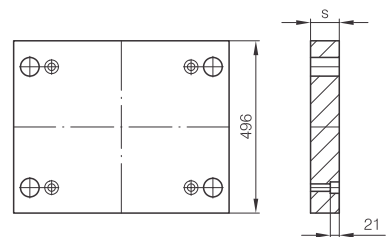

| S  | Material                 |                          |
|----|--------------------------|--------------------------|
|    | 1.1730                   | 1.2312                   |
| 36 | <input type="checkbox"/> | <input type="checkbox"/> |
| 46 | <input type="checkbox"/> | <input type="checkbox"/> |



**2115 H**

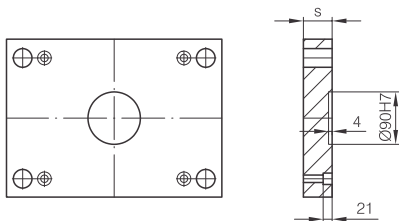

| S  | Material                 |                          |
|----|--------------------------|--------------------------|
|    | 1.1730                   | 1.2312                   |
| 27 | <input type="checkbox"/> | <input type="checkbox"/> |
| 36 | <input type="checkbox"/> | <input type="checkbox"/> |



**2116 H**

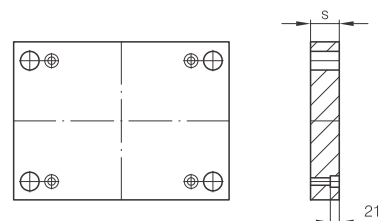

| S  | Material                 |                          |                          |
|----|--------------------------|--------------------------|--------------------------|
|    | 1.1730                   | 1.2162                   | 1.2312                   |
| 27 | <input type="checkbox"/> | <input type="checkbox"/> | <input type="checkbox"/> |
| 36 | <input type="checkbox"/> | <input type="checkbox"/> | <input type="checkbox"/> |



2120 H

2125 H

## 396 x 546

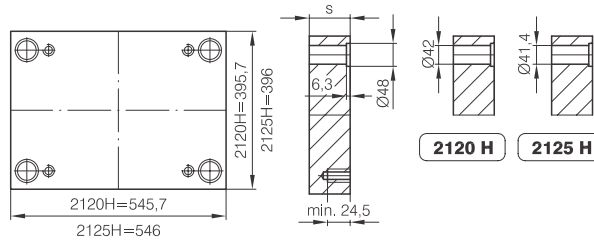

| S   | Material |        |        |        |        |        |        |        |
|-----|----------|--------|--------|--------|--------|--------|--------|--------|
|     | 1.1730   | 1.2162 | 1.2767 | 1.2083 | 1.2085 | 1.2311 | 1.2312 | 1.2343 |
| 27  | ■        | ■      | ■      |        | ■      | ■      | ■      |        |
| 36  | ■        |        |        |        | ■      |        |        |        |
| 46  | ■        | ■      | ■      |        | ■      | ■      | ■      |        |
| 56  | ■        | ■      | ■      |        | ■      |        | ■      | ■      |
| 66  | ■        |        |        |        | ■      |        | ■      |        |
| 76  | ■        | ■      | ■      |        | ■      | ■      | ■      | ■      |
| 86  | ■        |        |        |        | ■      |        | ■      |        |
| 96  | ■        | ■      | ■      |        | ■      | ■      | ■      | ■      |
| 116 | ■        | ■      | ■      |        | ■      | ■      | ■      | ■      |
| 136 | ■        | ■      | ■      |        | ■      | ■      | ■      | ■      |



2130 H



2140 H



| S  | Material |        |
|----|----------|--------|
|    | 1.1730   | 1.2312 |
| 46 | ■        | ■      |
| 56 | ■        | ■      |

| S   | Material |        |
|-----|----------|--------|
|     | 1.1730   | 1.2312 |
| 66  | ■        |        |
| 76  | ■        |        |
| 86  | ■        |        |
| 96  | ■        |        |
| 116 | ■        |        |
| 136 | ■        |        |



2160 H



2170 H



| S  | Material |        |
|----|----------|--------|
|    | 1.1730   | 1.2312 |
| 17 | ■        |        |

| S  | Material |        |
|----|----------|--------|
|    | 1.1730   | 1.2312 |
| 27 | ■        | ■      |

# 396 x 596

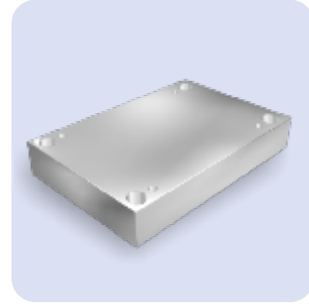
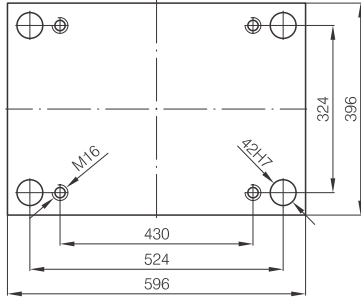

**2110 H**

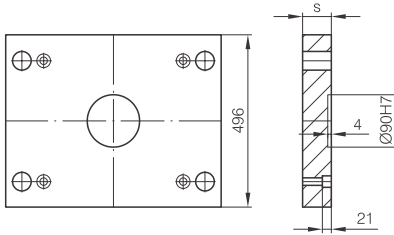

| S  | Material                 |                          |
|----|--------------------------|--------------------------|
|    | 1.1730                   | 1.2312                   |
| 36 | <input type="checkbox"/> | <input type="checkbox"/> |
| 46 | <input type="checkbox"/> | <input type="checkbox"/> |



**2111 H**

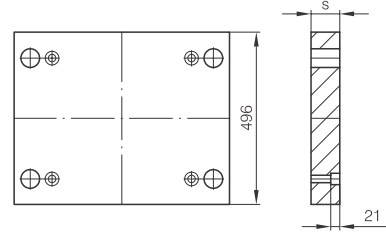

| S  | Material                 |                          |
|----|--------------------------|--------------------------|
|    | 1.1730                   | 1.2312                   |
| 36 | <input type="checkbox"/> | <input type="checkbox"/> |
| 46 | <input type="checkbox"/> | <input type="checkbox"/> |



**2115 H**

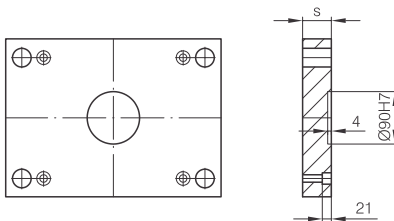

| S  | Material                 |                          |
|----|--------------------------|--------------------------|
|    | 1.1730                   | 1.2312                   |
| 27 | <input type="checkbox"/> | <input type="checkbox"/> |
| 36 | <input type="checkbox"/> | <input type="checkbox"/> |



**2116 H**

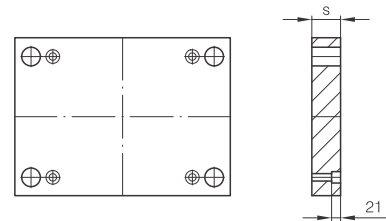

| S  | Material                 |                          |                          |
|----|--------------------------|--------------------------|--------------------------|
|    | 1.1730                   | 1.2162                   | 1.2312                   |
| 27 | <input type="checkbox"/> | <input type="checkbox"/> | <input type="checkbox"/> |
| 36 | <input type="checkbox"/> | <input type="checkbox"/> | <input type="checkbox"/> |



2120 H

2125 H

## 396 x 596

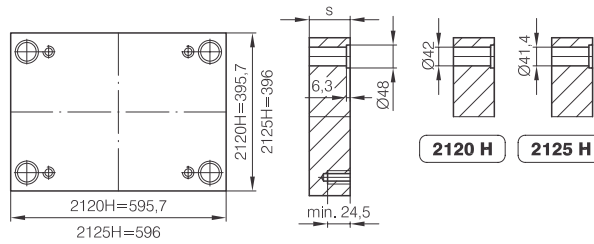

| S   | Material |        |        |        |        |        |        |        |
|-----|----------|--------|--------|--------|--------|--------|--------|--------|
|     | 1.1730   | 1.2162 | 1.2767 | 1.2083 | 1.2085 | 1.2311 | 1.2312 | 1.2343 |
| 27  | ■        |        |        |        | ■      |        | ■      |        |
| 36  | ■        |        |        |        | ■      | ■      | ■      |        |
| 46  | ■        |        |        |        | ■      | ■      | ■      |        |
| 56  | ■        |        |        |        | ■      | ■      | ■      | ■      |
| 66  | ■        |        |        |        | ■      | ■      | ■      |        |
| 76  | ■        |        |        |        | ■      | ■      | ■      | ■      |
| 86  | ■        |        |        |        | ■      | ■      | ■      |        |
| 96  | ■        |        |        |        | ■      | ■      | ■      | ■      |
| 116 | ■        |        |        |        | ■      | ■      | ■      | ■      |
| 136 | ■        |        |        |        | ■      | ■      | ■      | ■      |



2130 H



2140 H

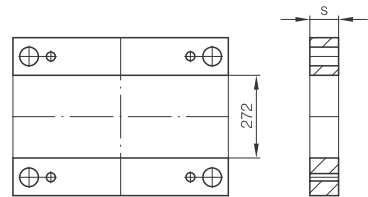
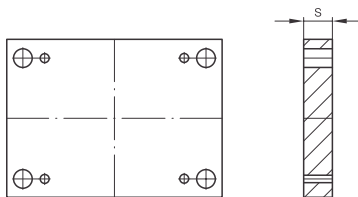

| S  | Material |        |
|----|----------|--------|
|    | 1.1730   | 1.2312 |
| 46 | ■        | ■      |
| 56 | ■        | ■      |

| S   | Material |        |
|-----|----------|--------|
|     | 1.1730   | 1.2312 |
| 66  | ■        |        |
| 76  | ■        |        |
| 86  | ■        |        |
| 96  | ■        |        |
| 116 | ■        |        |
| 136 | ■        |        |



2160 H



2170 H

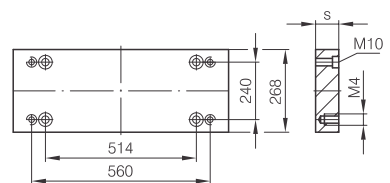
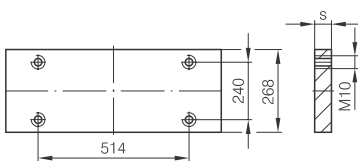

| S  | Material |        |
|----|----------|--------|
|    | 1.1730   | 1.2312 |
| 22 | ■        |        |

| S  | Material |        |
|----|----------|--------|
|    | 1.1730   | 1.2312 |
| 27 | ■        | ■      |

# 446 x 446

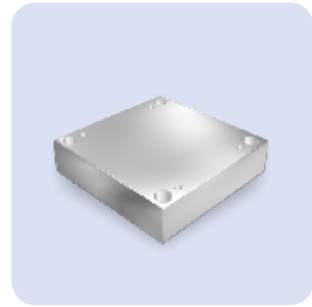
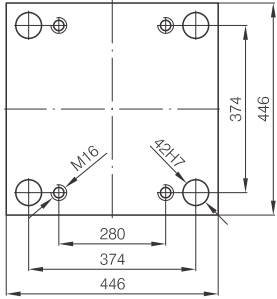

**2110 H**

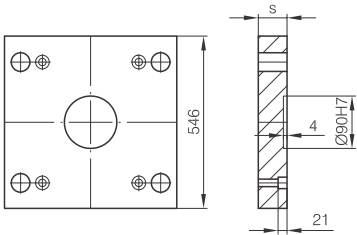

| S  | Material                 |                          |
|----|--------------------------|--------------------------|
|    | 1.1730                   | 1.2312                   |
| 36 | <input type="checkbox"/> | <input type="checkbox"/> |
| 46 | <input type="checkbox"/> | <input type="checkbox"/> |



**2111 H**

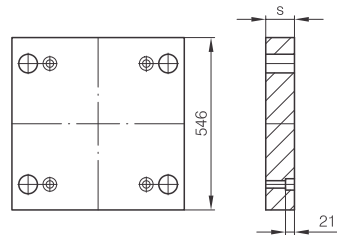

| S  | Material                 |                          |
|----|--------------------------|--------------------------|
|    | 1.1730                   | 1.2312                   |
| 36 | <input type="checkbox"/> | <input type="checkbox"/> |
| 46 | <input type="checkbox"/> | <input type="checkbox"/> |



**2115 H**

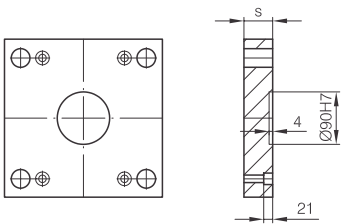

| S  | Material                 |                          |
|----|--------------------------|--------------------------|
|    | 1.1730                   | 1.2312                   |
| 27 | <input type="checkbox"/> | <input type="checkbox"/> |
| 36 | <input type="checkbox"/> | <input type="checkbox"/> |



**2116 H**

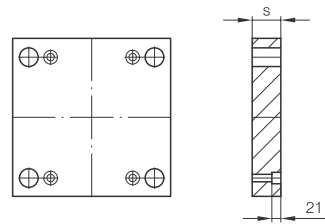

| S  | Material                 |                          |                          |
|----|--------------------------|--------------------------|--------------------------|
|    | 1.1730                   | 1.2162                   | 1.2312                   |
| 36 | <input type="checkbox"/> | <input type="checkbox"/> | <input type="checkbox"/> |
| 46 | <input type="checkbox"/> | <input type="checkbox"/> | <input type="checkbox"/> |



2120 H

2125 H

## 446 x 446

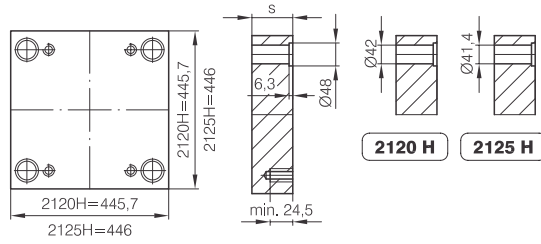

| S   | Material |        |        |        |        |        |        |        |
|-----|----------|--------|--------|--------|--------|--------|--------|--------|
|     | 1.1730   | 1.2162 | 1.2767 | 1.2083 | 1.2085 | 1.2311 | 1.2312 | 1.2343 |
| 27  | ■        |        |        |        | ■      |        | ■      |        |
| 36  | ■        | ■      |        |        | ■      | ■      | ■      |        |
| 46  | ■        | ■      |        |        | ■      | ■      | ■      |        |
| 56  | ■        | ■      |        |        | ■      | ■      | ■      | ■      |
| 66  | ■        |        |        |        | ■      |        | ■      |        |
| 76  | ■        | ■      |        |        | ■      | ■      | ■      | ■      |
| 86  | ■        |        |        |        | ■      |        | ■      |        |
| 96  | ■        | ■      |        |        | ■      | ■      | ■      | ■      |
| 116 | ■        | ■      |        |        | ■      | ■      | ■      | ■      |



2130 H



2140 H

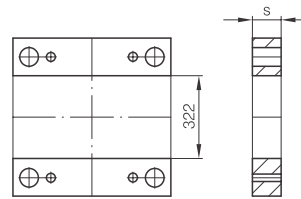
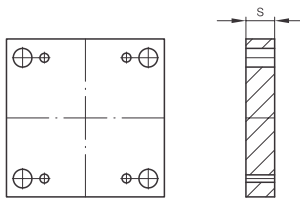

| S  | Material |        |
|----|----------|--------|
|    | 1.1730   | 1.2312 |
| 36 | ■        |        |
| 46 | ■        | ■      |

| S   | Material |        |
|-----|----------|--------|
|     | 1.1730   | 1.2312 |
| 56  | ■        |        |
| 66  | ■        |        |
| 76  | ■        |        |
| 86  | ■        |        |
| 96  | ■        |        |
| 116 | ■        |        |



2160 H



2170 H

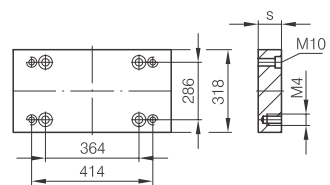
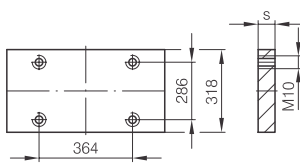

| S  | Material |        |
|----|----------|--------|
|    | 1.1730   | 1.2312 |
| 17 | ■        |        |

| S  | Material |        |
|----|----------|--------|
|    | 1.1730   | 1.2312 |
| 27 | ■        | ■      |

# 446 x 496

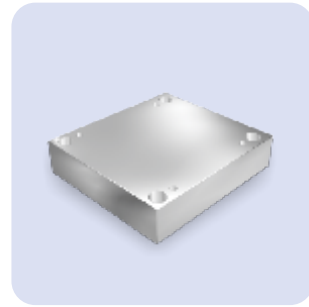
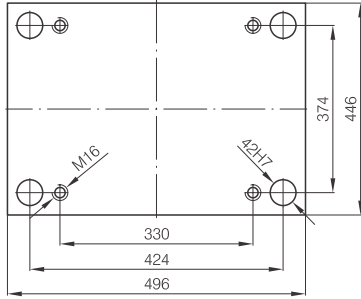

**2110 H**

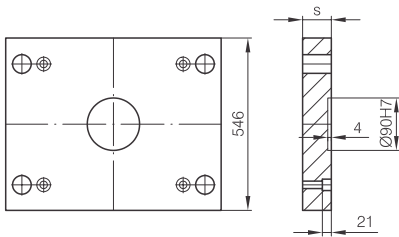

| S  | Material                 |                          |
|----|--------------------------|--------------------------|
|    | 1.1730                   | 1.2312                   |
| 36 | <input type="checkbox"/> | <input type="checkbox"/> |
| 46 | <input type="checkbox"/> | <input type="checkbox"/> |



**2111 H**

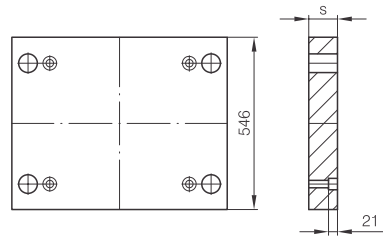

| S  | Material                 |                          |
|----|--------------------------|--------------------------|
|    | 1.1730                   | 1.2312                   |
| 36 | <input type="checkbox"/> | <input type="checkbox"/> |
| 46 | <input type="checkbox"/> | <input type="checkbox"/> |



**2115 H**

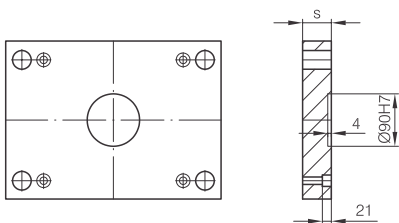

| S  | Material                 |                          |
|----|--------------------------|--------------------------|
|    | 1.1730                   | 1.2312                   |
| 27 | <input type="checkbox"/> | <input type="checkbox"/> |
| 36 | <input type="checkbox"/> | <input type="checkbox"/> |



**2116 H**

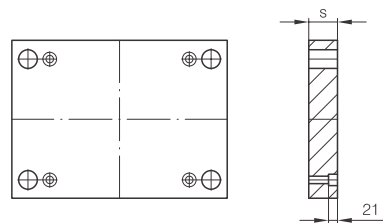

| S  | Material                 |                          |                          |
|----|--------------------------|--------------------------|--------------------------|
|    | 1.1730                   | 1.2162                   | 1.2312                   |
| 27 | <input type="checkbox"/> | <input type="checkbox"/> | <input type="checkbox"/> |
| 36 | <input type="checkbox"/> | <input type="checkbox"/> | <input type="checkbox"/> |



2120 H

2125 H

## 446 x 496

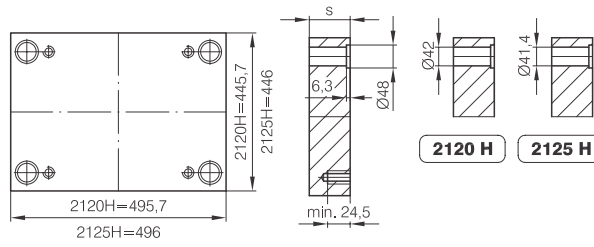

| S   | Material |        |        |        |        |        |        |        |
|-----|----------|--------|--------|--------|--------|--------|--------|--------|
|     | 1.1730   | 1.2162 | 1.2767 | 1.2083 | 1.2085 | 1.2311 | 1.2312 | 1.2343 |
| 27  | ■        |        |        |        | ■      |        | ■      |        |
| 36  | ■        |        |        |        | ■      | ■      | ■      |        |
| 46  | ■        |        |        |        | ■      | ■      | ■      |        |
| 56  | ■        |        |        |        | ■      | ■      | ■      | ■      |
| 66  | ■        |        |        |        | ■      |        | ■      |        |
| 76  | ■        |        |        |        | ■      | ■      | ■      | ■      |
| 86  | ■        |        |        |        | ■      |        | ■      |        |
| 96  | ■        |        |        |        | ■      | ■      | ■      | ■      |
| 116 | ■        |        |        |        | ■      | ■      | ■      | ■      |
| 136 | ■        |        |        |        | ■      | ■      | ■      | ■      |



2130 H



2140 H

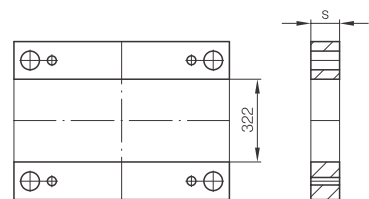
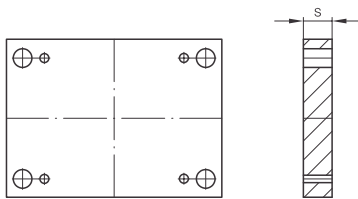

| S  | Material |        |
|----|----------|--------|
|    | 1.1730   | 1.2312 |
| 46 | ■        | ■      |
| 56 | ■        | ■      |

| S   | Material |        |
|-----|----------|--------|
|     | 1.1730   | 1.2312 |
| 66  | ■        |        |
| 76  | ■        |        |
| 86  | ■        |        |
| 96  | ■        |        |
| 116 | ■        |        |
| 136 | ■        |        |



2160 H



2170 H

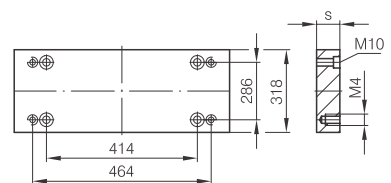
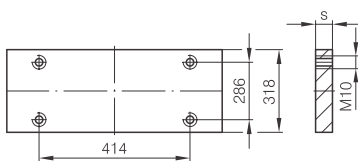

| S  | Material |        |
|----|----------|--------|
|    | 1.1730   | 1.2312 |
| 22 | ■        |        |

| S  | Material |        |
|----|----------|--------|
|    | 1.1730   | 1.2312 |
| 27 | ■        | ■      |

# 446 x 546

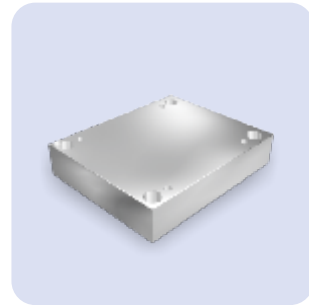
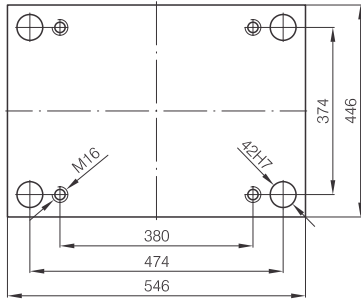

**2110 H**

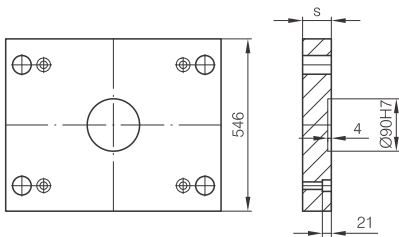

| S  | Material                            |                                     |
|----|-------------------------------------|-------------------------------------|
|    | 1.1730                              | 1.2312                              |
| 36 | <input checked="" type="checkbox"/> |                                     |
| 46 | <input checked="" type="checkbox"/> | <input checked="" type="checkbox"/> |



**2111 H**

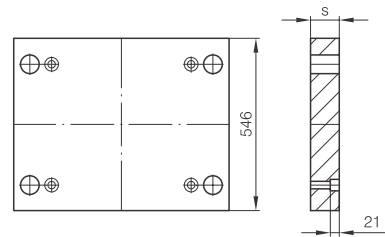

| S  | Material                            |                                     |
|----|-------------------------------------|-------------------------------------|
|    | 1.1730                              | 1.2312                              |
| 36 | <input checked="" type="checkbox"/> |                                     |
| 46 | <input checked="" type="checkbox"/> | <input checked="" type="checkbox"/> |



**2115 H**

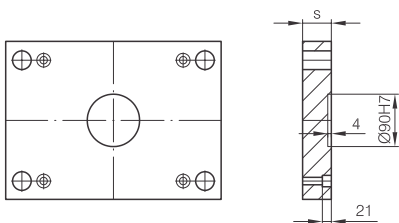

| S  | Material                            |                                     |
|----|-------------------------------------|-------------------------------------|
|    | 1.1730                              | 1.2312                              |
| 27 | <input checked="" type="checkbox"/> |                                     |
| 36 | <input checked="" type="checkbox"/> | <input checked="" type="checkbox"/> |



**2116 H**

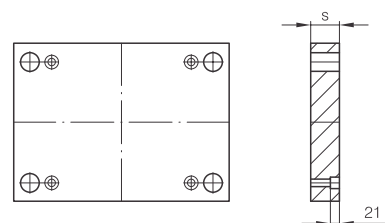

| S  | Material                            |        |                                     |
|----|-------------------------------------|--------|-------------------------------------|
|    | 1.1730                              | 1.2162 | 1.2312                              |
| 27 | <input checked="" type="checkbox"/> |        |                                     |
| 36 | <input checked="" type="checkbox"/> |        | <input checked="" type="checkbox"/> |



2120 H

2125 H

# 446 x 546

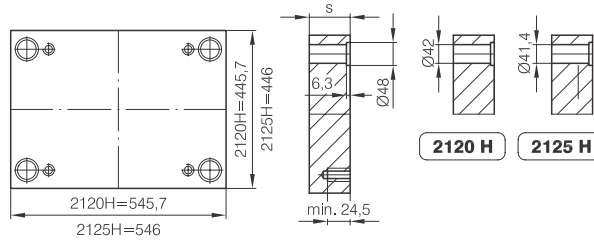

| S   | Material |        |        |        |        |        |        |        |
|-----|----------|--------|--------|--------|--------|--------|--------|--------|
|     | 1.1730   | 1.2162 | 1.2767 | 1.2083 | 1.2085 | 1.2311 | 1.2312 | 1.2343 |
| 27  | ■        |        |        |        | ■      |        | ■      |        |
| 36  | ■        |        |        |        | ■      | ■      | ■      |        |
| 46  | ■        |        |        |        | ■      | ■      | ■      |        |
| 56  | ■        |        |        |        | ■      | ■      | ■      | ■      |
| 66  | ■        |        |        |        | ■      | ■      | ■      |        |
| 76  | ■        |        |        |        | ■      | ■      | ■      | ■      |
| 86  | ■        |        |        |        | ■      | ■      | ■      |        |
| 96  | ■        |        |        |        | ■      | ■      | ■      | ■      |
| 116 | ■        |        |        |        | ■      | ■      | ■      | ■      |
| 136 | ■        |        |        |        | ■      | ■      | ■      | ■      |



2130 H



2140 H

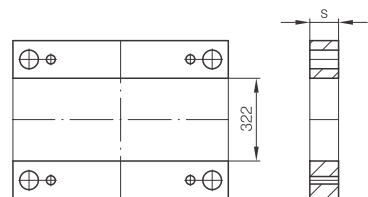
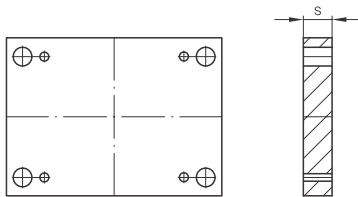

| S  | Material |        |
|----|----------|--------|
|    | 1.1730   | 1.2312 |
| 46 | ■        | ■      |
| 56 | ■        | ■      |

| S   | Material |        |
|-----|----------|--------|
|     | 1.1730   | 1.2312 |
| 66  | ■        |        |
| 76  | ■        |        |
| 86  | ■        |        |
| 96  | ■        |        |
| 116 | ■        |        |
| 136 | ■        |        |



2160 H



2170 H

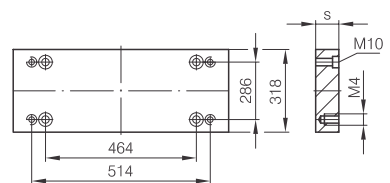
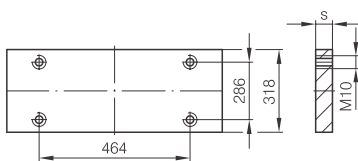

| S  | Material |        |
|----|----------|--------|
|    | 1.1730   | 1.2312 |
| 22 | ■        |        |

| S  | Material |        |
|----|----------|--------|
|    | 1.1730   | 1.2312 |
| 27 | ■        | ■      |

# 446 x 596

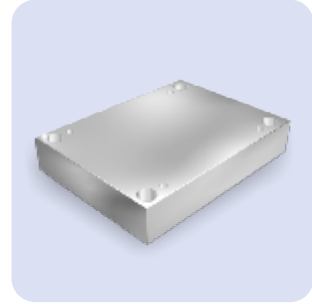
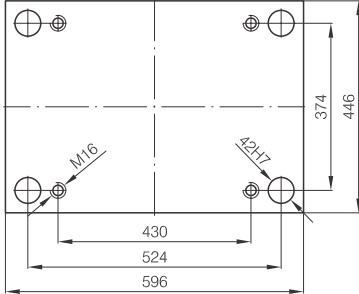

**2110 H**

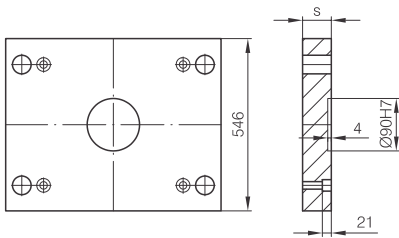

| S  | Material                            |                                     |
|----|-------------------------------------|-------------------------------------|
|    | 1.1730                              | 1.2312                              |
| 36 | <input checked="" type="checkbox"/> |                                     |
| 46 | <input checked="" type="checkbox"/> | <input checked="" type="checkbox"/> |



**2111 H**

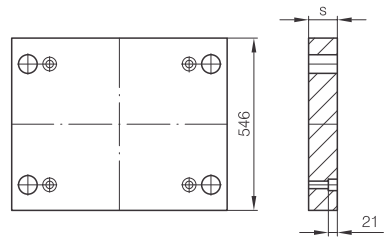

| S  | Material                            |                                     |
|----|-------------------------------------|-------------------------------------|
|    | 1.1730                              | 1.2312                              |
| 36 | <input checked="" type="checkbox"/> |                                     |
| 46 | <input checked="" type="checkbox"/> | <input checked="" type="checkbox"/> |



**2115 H**

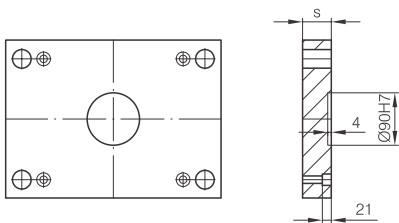

| S  | Material                            |                                     |
|----|-------------------------------------|-------------------------------------|
|    | 1.1730                              | 1.2312                              |
| 27 | <input checked="" type="checkbox"/> |                                     |
| 36 | <input checked="" type="checkbox"/> | <input checked="" type="checkbox"/> |



**2116 H**

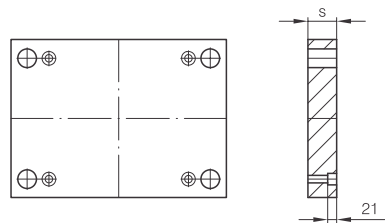

| S  | Material                            |        |                                     |
|----|-------------------------------------|--------|-------------------------------------|
|    | 1.1730                              | 1.2162 | 1.2312                              |
| 27 | <input checked="" type="checkbox"/> |        |                                     |
| 36 | <input checked="" type="checkbox"/> |        | <input checked="" type="checkbox"/> |



2120 H

2125 H

# 446 x 596

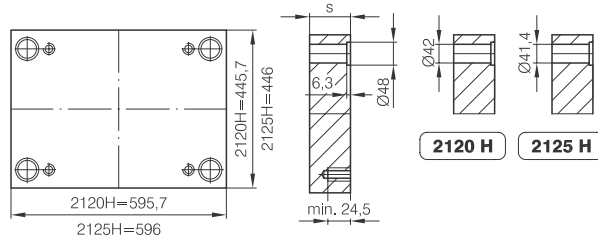

| S   | Material |        |        |        |        |        |        |        |
|-----|----------|--------|--------|--------|--------|--------|--------|--------|
|     | 1.1730   | 1.2162 | 1.2767 | 1.2083 | 1.2085 | 1.2311 | 1.2312 | 1.2343 |
| 27  | ■        |        |        |        | ■      |        | ■      |        |
| 36  | ■        |        |        |        | ■      | ■      | ■      |        |
| 46  | ■        |        |        |        | ■      | ■      | ■      |        |
| 56  | ■        |        |        |        | ■      | ■      | ■      | ■      |
| 66  | ■        |        |        |        | ■      |        | ■      |        |
| 76  | ■        |        |        |        | ■      | ■      | ■      | ■      |
| 86  | ■        |        |        |        | ■      |        | ■      |        |
| 96  | ■        |        |        |        | ■      | ■      | ■      | ■      |
| 116 | ■        |        |        |        | ■      | ■      | ■      | ■      |
| 136 | ■        |        |        |        | ■      | ■      | ■      | ■      |



2130 H



2140 H

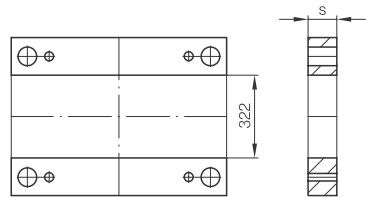
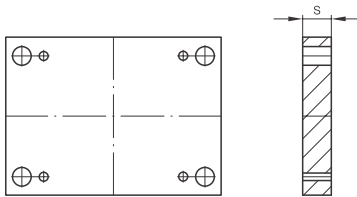

| S  | Material |        |
|----|----------|--------|
|    | 1.1730   | 1.2312 |
| 46 | ■        | ■      |
| 56 | ■        | ■      |

| S   | Material |        |
|-----|----------|--------|
|     | 1.1730   | 1.2312 |
| 66  | ■        |        |
| 76  | ■        |        |
| 86  | ■        |        |
| 96  | ■        |        |
| 116 | ■        |        |
| 136 | ■        |        |



2160 H



2170 H

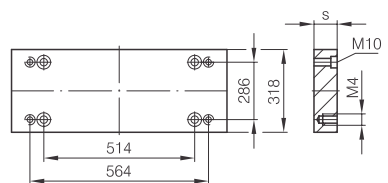
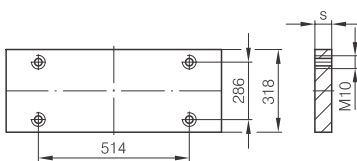

| S  | Material |        |
|----|----------|--------|
|    | 1.1730   | 1.2312 |
| 22 | ■        |        |

| S  | Material |        |
|----|----------|--------|
|    | 1.1730   | 1.2312 |
| 27 | ■        | ■      |

# 496 x 496

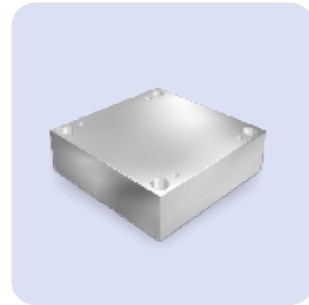
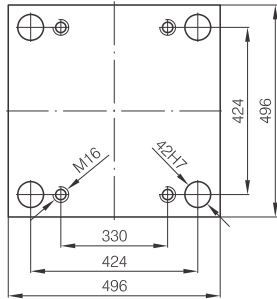

**2110 H**

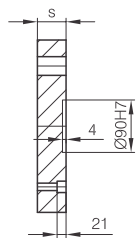
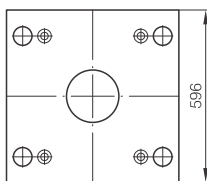

| S  | Material |        |
|----|----------|--------|
|    | 1.1730   | 1.2312 |
| 36 | ■        |        |
| 46 | ■        |        |
| 56 | ■        | ■      |



**2111 H**

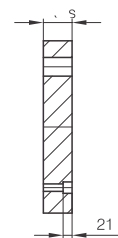
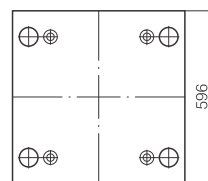

| S  | Material |        |
|----|----------|--------|
|    | 1.1730   | 1.2312 |
| 36 | ■        |        |
| 46 | ■        |        |
| 56 | ■        | ■      |



**2115 H**

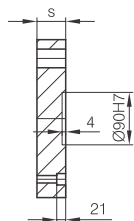
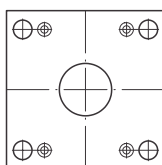

| S  | Material |        |
|----|----------|--------|
|    | 1.1730   | 1.2312 |
| 27 | ■        |        |
| 36 | ■        |        |
| 46 | ■        | ■      |



**2116 H**

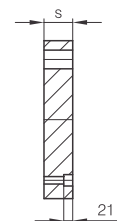
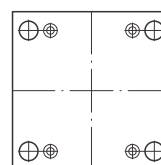

| S  | Material |        |        |
|----|----------|--------|--------|
|    | 1.1730   | 1.2162 | 1.2312 |
| 27 | ■        |        |        |
| 36 | ■        |        |        |
| 46 | ■        |        | ■      |



2120 H

2125 H

## 496 x 496

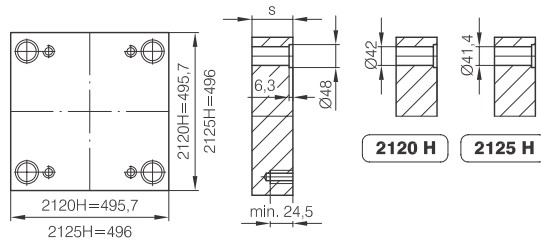

| S   | Material |        |        |        |        |        |        |        |
|-----|----------|--------|--------|--------|--------|--------|--------|--------|
|     | 1.1730   | 1.2162 | 1.2767 | 1.2083 | 1.2085 | 1.2311 | 1.2312 | 1.2343 |
| 27  | ■        |        |        |        | ■      |        | ■      |        |
| 36  | ■        |        |        |        | ■      |        | ■      |        |
| 46  | ■        |        |        |        | ■      | ■      | ■      |        |
| 56  | ■        |        |        |        | ■      | ■      | ■      |        |
| 66  | ■        |        |        |        | ■      |        | ■      |        |
| 76  | ■        |        |        |        | ■      | ■      | ■      | ■      |
| 86  | ■        |        |        |        | ■      |        | ■      |        |
| 96  | ■        |        |        |        | ■      | ■      | ■      | ■      |
| 116 | ■        |        |        |        | ■      | ■      | ■      | ■      |
| 136 | ■        |        |        |        | ■      | ■      | ■      | ■      |
| 156 | ■        |        |        |        | ■      | ■      | ■      | ■      |



2130 H



2140 H

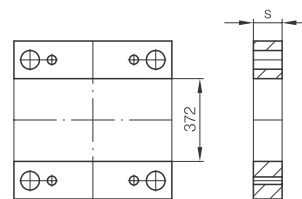
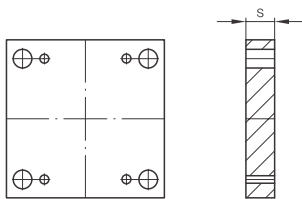

| S  | Material |        |
|----|----------|--------|
|    | 1.1730   | 1.2312 |
| 46 | ■        |        |
| 56 | ■        | ■      |

| S   | Material |        |
|-----|----------|--------|
|     | 1.1730   | 1.2312 |
| 66  | ■        |        |
| 76  | ■        |        |
| 86  | ■        |        |
| 96  | ■        |        |
| 116 | ■        |        |
| 136 | ■        |        |



2160 H



2170 H

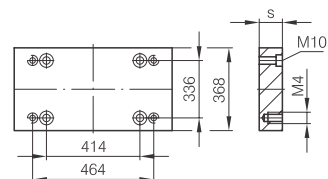
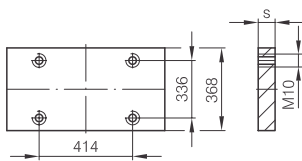

| S  | Material |        |
|----|----------|--------|
|    | 1.1730   | 1.2312 |
| 27 | ■        |        |

| S  | Material |        |
|----|----------|--------|
|    | 1.1730   | 1.2312 |
| 36 | ■        | ■      |

# 496 x 546

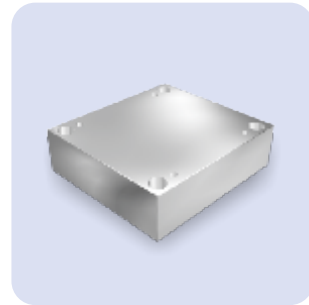
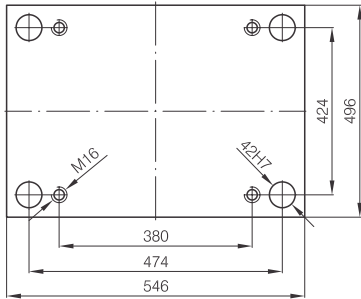

**2110 H**

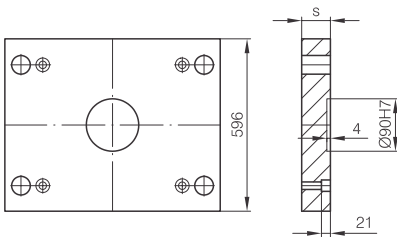

| S  | Material |        |
|----|----------|--------|
|    | 1.1730   | 1.2312 |
| 36 | ■        |        |
| 46 | ■        |        |
| 56 | ■        | ■      |



**2111 H**

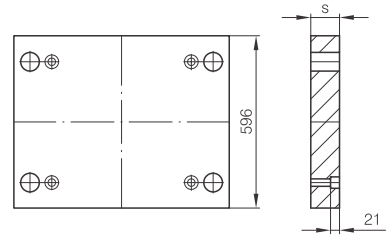

| S  | Material |        |
|----|----------|--------|
|    | 1.1730   | 1.2312 |
| 36 | ■        |        |
| 46 | ■        |        |
| 56 | ■        | ■      |



**2115 H**

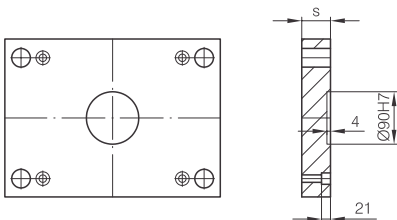

| S  | Material |        |
|----|----------|--------|
|    | 1.1730   | 1.2312 |
| 27 | ■        |        |
| 36 | ■        |        |
| 46 | ■        | ■      |



**2116 H**

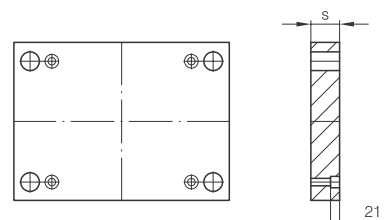

| S  | Material |        |        |
|----|----------|--------|--------|
|    | 1.1730   | 1.2162 | 1.2312 |
| 27 | ■        |        |        |
| 36 | ■        |        |        |
| 46 | ■        |        | ■      |



2120 H

2125 H

## 496 x 546

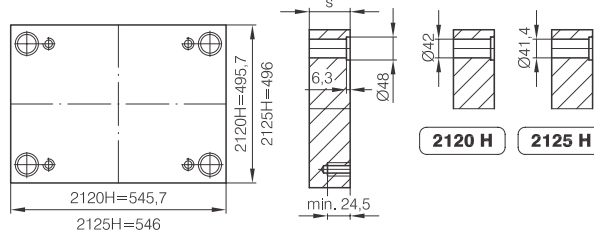

| S   | Material |        |        |        |        |        |        |        |
|-----|----------|--------|--------|--------|--------|--------|--------|--------|
|     | 1.1730   | 1.2162 | 1.2767 | 1.2083 | 1.2085 | 1.2311 | 1.2312 | 1.2343 |
| 27  | ■        |        |        |        | ■      |        | ■      |        |
| 36  | ■        |        |        |        | ■      |        | ■      |        |
| 46  | ■        |        |        |        | ■      | ■      | ■      |        |
| 56  | ■        |        |        |        | ■      |        | ■      |        |
| 66  | ■        |        |        |        | ■      | ■      | ■      |        |
| 76  | ■        |        |        |        | ■      | ■      | ■      | ■      |
| 86  | ■        |        |        |        | ■      |        | ■      |        |
| 96  | ■        |        |        |        | ■      | ■      | ■      | ■      |
| 116 | ■        |        |        |        | ■      | ■      | ■      | ■      |
| 136 | ■        |        |        |        | ■      | ■      | ■      | ■      |
| 156 | ■        |        |        |        | ■      | ■      | ■      | ■      |



2130 H



2140 H



| S  | Material |        |
|----|----------|--------|
|    | 1.1730   | 1.2312 |
| 46 | ■        |        |
| 56 | ■        | ■      |

| S   | Material |        |
|-----|----------|--------|
|     | 1.1730   | 1.2312 |
| 66  | ■        |        |
| 76  | ■        |        |
| 86  | ■        |        |
| 96  | ■        |        |
| 116 | ■        |        |
| 136 | ■        |        |



2160 H



2170 H

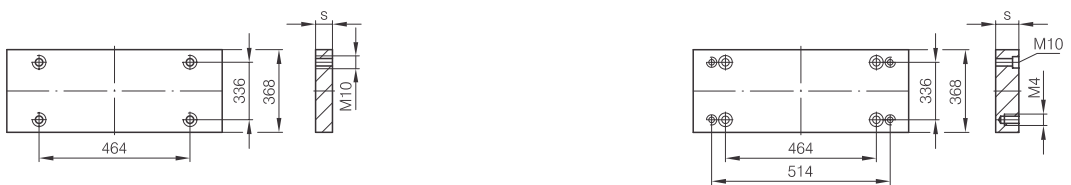

| S  | Material |        |
|----|----------|--------|
|    | 1.1730   | 1.2312 |
| 27 | ■        |        |

| S  | Material |        |
|----|----------|--------|
|    | 1.1730   | 1.2312 |
| 36 | ■        | ■      |

# 496 x 596

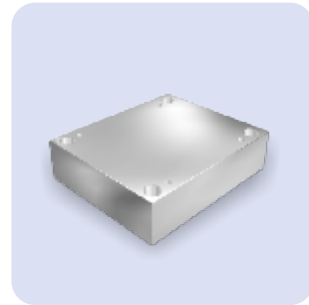
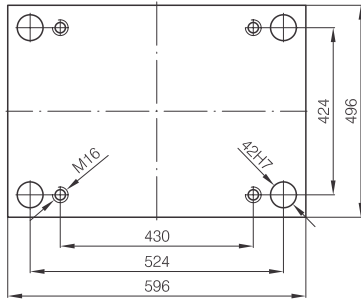

**2110 H**

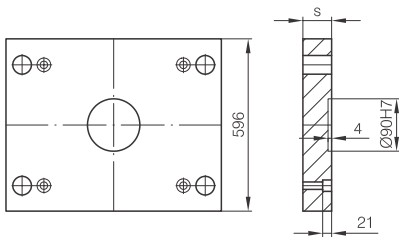

| S  | Material                            |                                     |
|----|-------------------------------------|-------------------------------------|
|    | 1.1730                              | 1.2312                              |
| 46 | <input checked="" type="checkbox"/> | <input type="checkbox"/>            |
| 56 | <input checked="" type="checkbox"/> | <input checked="" type="checkbox"/> |



**2111 H**

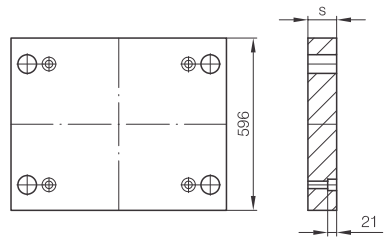

| S  | Material                            |                                     |
|----|-------------------------------------|-------------------------------------|
|    | 1.1730                              | 1.2312                              |
| 46 | <input checked="" type="checkbox"/> | <input type="checkbox"/>            |
| 56 | <input checked="" type="checkbox"/> | <input checked="" type="checkbox"/> |



**2115 H**

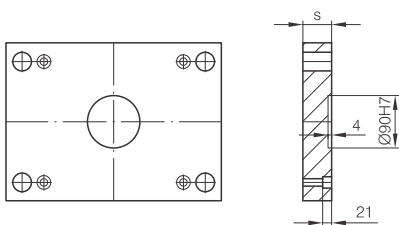

| S  | Material                            |                                     |
|----|-------------------------------------|-------------------------------------|
|    | 1.1730                              | 1.2312                              |
| 36 | <input checked="" type="checkbox"/> | <input type="checkbox"/>            |
| 46 | <input checked="" type="checkbox"/> | <input checked="" type="checkbox"/> |



**2116 H**

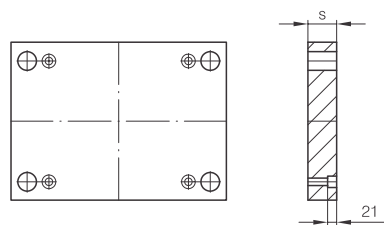

| S  | Material                            |                          |                                     |
|----|-------------------------------------|--------------------------|-------------------------------------|
|    | 1.1730                              | 1.2162                   | 1.2312                              |
| 36 | <input checked="" type="checkbox"/> | <input type="checkbox"/> | <input type="checkbox"/>            |
| 46 | <input checked="" type="checkbox"/> | <input type="checkbox"/> | <input checked="" type="checkbox"/> |



2120 H

2125 H

## 496 x 596

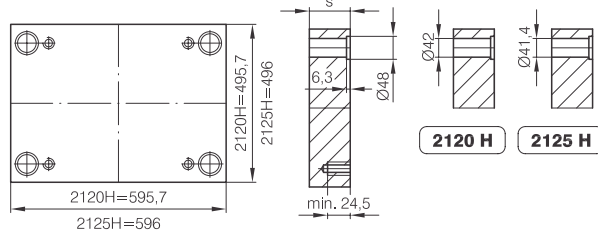

| S   | Material |        |        |        |        |        |        |        |
|-----|----------|--------|--------|--------|--------|--------|--------|--------|
|     | 1.1730   | 1.2162 | 1.2767 | 1.2083 | 1.2085 | 1.2311 | 1.2312 | 1.2343 |
| 36  | ■        |        |        |        | ■      |        | ■      |        |
| 46  | ■        |        |        |        | ■      | ■      | ■      |        |
| 56  | ■        |        |        |        | ■      | ■      | ■      |        |
| 66  | ■        |        |        |        | ■      |        | ■      |        |
| 76  | ■        |        |        |        | ■      | ■      | ■      | ■      |
| 86  | ■        |        |        |        | ■      |        | ■      |        |
| 96  | ■        |        |        |        | ■      | ■      | ■      | ■      |
| 116 | ■        |        |        |        | ■      | ■      | ■      | ■      |
| 136 | ■        |        |        |        | ■      | ■      | ■      | ■      |
| 156 | ■        |        |        |        | ■      | ■      | ■      | ■      |



2130 H



2140 H

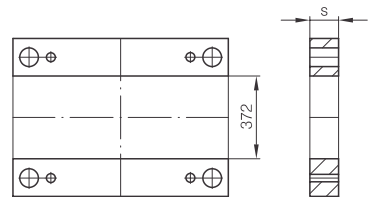
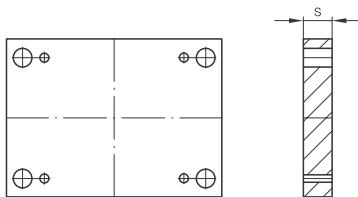

| S  | Material |        |
|----|----------|--------|
|    | 1.1730   | 1.2312 |
| 46 | ■        |        |
| 56 | ■        | ■      |

| S   | Material |        |
|-----|----------|--------|
|     | 1.1730   | 1.2312 |
| 76  | ■        |        |
| 86  | ■        |        |
| 96  | ■        |        |
| 116 | ■        |        |
| 136 | ■        |        |



2160 H



2170 H

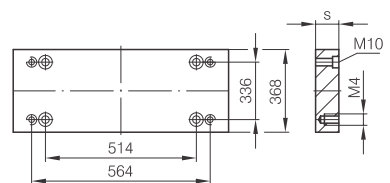
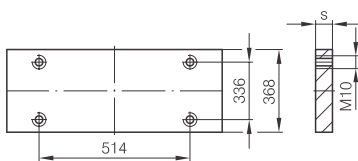

| S  | Material |        |
|----|----------|--------|
|    | 1.1730   | 1.2312 |
| 27 | ■        |        |

| S  | Material |        |
|----|----------|--------|
|    | 1.1730   | 1.2312 |
| 36 | ■        | ■      |

# 496 x 696

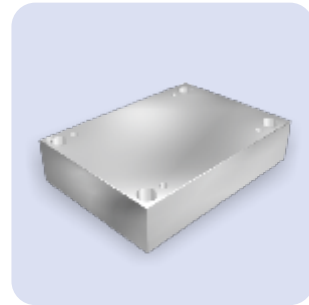
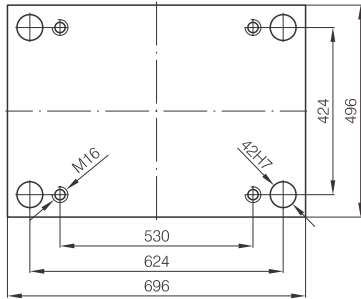

**2110 H**

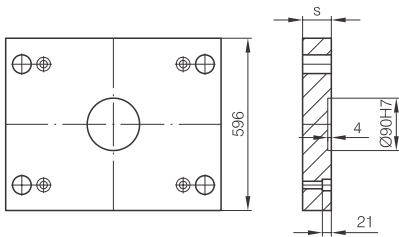

| S  | Material                            |                                     |
|----|-------------------------------------|-------------------------------------|
|    | 1.1730                              | 1.2312                              |
| 46 | <input checked="" type="checkbox"/> | <input type="checkbox"/>            |
| 56 | <input checked="" type="checkbox"/> | <input checked="" type="checkbox"/> |



**2111 H**

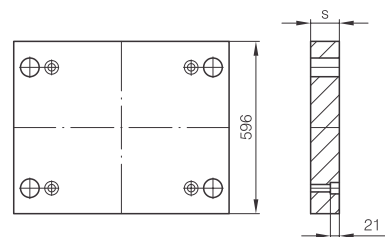

| S  | Material                            |                                     |
|----|-------------------------------------|-------------------------------------|
|    | 1.1730                              | 1.2312                              |
| 46 | <input checked="" type="checkbox"/> | <input type="checkbox"/>            |
| 56 | <input checked="" type="checkbox"/> | <input checked="" type="checkbox"/> |



**2115 H**

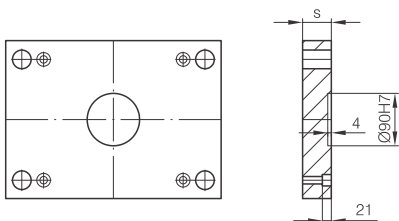

| S  | Material                            |                                     |
|----|-------------------------------------|-------------------------------------|
|    | 1.1730                              | 1.2312                              |
| 36 | <input checked="" type="checkbox"/> | <input type="checkbox"/>            |
| 46 | <input checked="" type="checkbox"/> | <input checked="" type="checkbox"/> |



**2116 H**

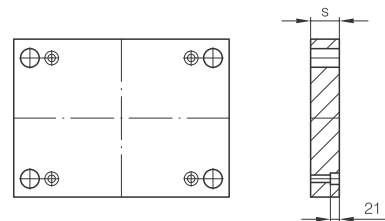

| S  | Material                            |                          |                                     |
|----|-------------------------------------|--------------------------|-------------------------------------|
|    | 1.1730                              | 1.2162                   | 1.2312                              |
| 36 | <input checked="" type="checkbox"/> | <input type="checkbox"/> | <input type="checkbox"/>            |
| 46 | <input checked="" type="checkbox"/> | <input type="checkbox"/> | <input checked="" type="checkbox"/> |



2120 H

2125 H

## 496 x 696

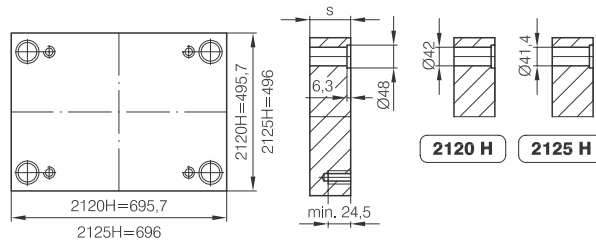

| S   | Material |        |        |        |        |        |        |        |
|-----|----------|--------|--------|--------|--------|--------|--------|--------|
|     | 1.1730   | 1.2162 | 1.2767 | 1.2083 | 1.2085 | 1.2311 | 1.2312 | 1.2343 |
| 36  | ■        |        |        |        | ■      |        | ■      |        |
| 46  | ■        |        |        |        | ■      | ■      | ■      |        |
| 56  | ■        |        |        |        | ■      | ■      | ■      |        |
| 66  | ■        |        |        |        | ■      |        | ■      |        |
| 76  | ■        |        |        |        | ■      | ■      | ■      |        |
| 86  | ■        |        |        |        | ■      |        | ■      |        |
| 96  | ■        |        |        |        | ■      | ■      | ■      |        |
| 116 | ■        |        |        |        | ■      | ■      | ■      |        |
| 136 | ■        |        |        |        | ■      | ■      | ■      |        |
| 156 | ■        |        |        |        | ■      | ■      | ■      |        |



2130 H



2140 H

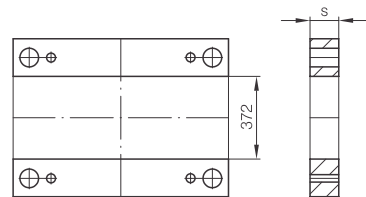
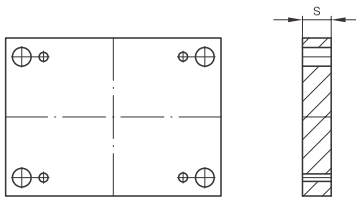

| S  | Material |        |
|----|----------|--------|
|    | 1.1730   | 1.2312 |
| 46 | ■        |        |
| 56 | ■        | ■      |

| S   | Material |        |
|-----|----------|--------|
|     | 1.1730   | 1.2312 |
| 76  | ■        |        |
| 86  | ■        |        |
| 96  | ■        |        |
| 116 | ■        |        |
| 136 | ■        |        |



2160 H



2170 H

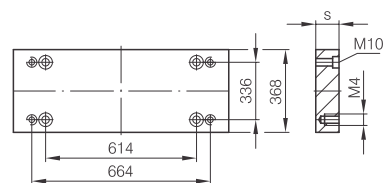
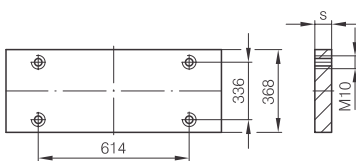

| S  | Material |        |
|----|----------|--------|
|    | 1.1730   | 1.2312 |
| 27 | ■        |        |

| S  | Material |        |
|----|----------|--------|
|    | 1.1730   | 1.2312 |
| 36 | ■        | ■      |

# 546 x 546

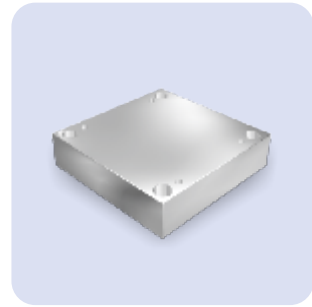
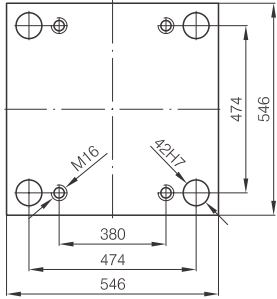

**2110 H**

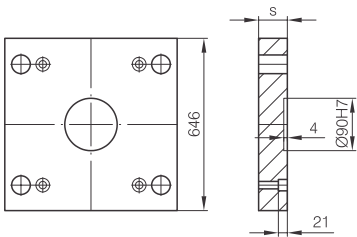

| S  | Material                            |                                     |
|----|-------------------------------------|-------------------------------------|
|    | 1.1730                              | 1.2312                              |
| 46 | <input checked="" type="checkbox"/> | <input type="checkbox"/>            |
| 56 | <input checked="" type="checkbox"/> | <input checked="" type="checkbox"/> |



**2111 H**

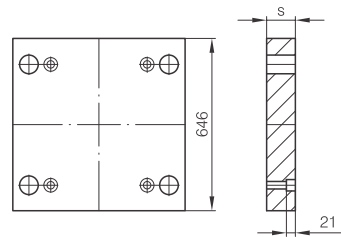

| S  | Material                            |                                     |
|----|-------------------------------------|-------------------------------------|
|    | 1.1730                              | 1.2312                              |
| 46 | <input checked="" type="checkbox"/> | <input type="checkbox"/>            |
| 56 | <input checked="" type="checkbox"/> | <input checked="" type="checkbox"/> |



**2115 H**

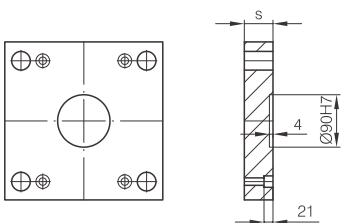

| S  | Material                            |                                     |
|----|-------------------------------------|-------------------------------------|
|    | 1.1730                              | 1.2312                              |
| 36 | <input checked="" type="checkbox"/> | <input type="checkbox"/>            |
| 46 | <input checked="" type="checkbox"/> | <input checked="" type="checkbox"/> |



**2116 H**

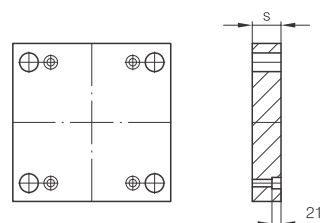

| S  | Material                            |                          |                                     |
|----|-------------------------------------|--------------------------|-------------------------------------|
|    | 1.1730                              | 1.2162                   | 1.2312                              |
| 36 | <input checked="" type="checkbox"/> | <input type="checkbox"/> | <input type="checkbox"/>            |
| 46 | <input checked="" type="checkbox"/> | <input type="checkbox"/> | <input checked="" type="checkbox"/> |



2120 H

2125 H

# 546 x 546

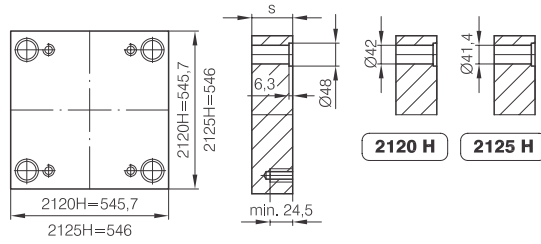

| S   | Material |        |        |        |        |        |        |        |
|-----|----------|--------|--------|--------|--------|--------|--------|--------|
|     | 1.1730   | 1.2162 | 1.2767 | 1.2083 | 1.2085 | 1.2311 | 1.2312 | 1.2343 |
| 36  | ■        |        |        |        | ■      |        | ■      |        |
| 46  | ■        |        |        |        | ■      | ■      | ■      |        |
| 56  | ■        |        |        |        | ■      | ■      | ■      |        |
| 66  | ■        |        |        |        | ■      |        | ■      |        |
| 76  | ■        |        |        |        | ■      | ■      | ■      | ■      |
| 86  | ■        |        |        |        | ■      |        | ■      |        |
| 96  | ■        |        |        |        | ■      | ■      | ■      | ■      |
| 116 | ■        |        |        |        | ■      | ■      | ■      | ■      |
| 136 | ■        |        |        |        | ■      | ■      | ■      | ■      |
| 156 | ■        |        |        |        | ■      | ■      | ■      | ■      |



2130 H



2140 H

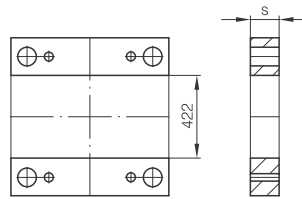
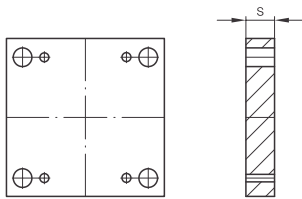

| S  | Material |        |
|----|----------|--------|
|    | 1.1730   | 1.2312 |
| 46 | ■        |        |
| 56 | ■        | ■      |

| S   | Material |        |
|-----|----------|--------|
|     | 1.1730   | 1.2312 |
| 76  | ■        |        |
| 86  | ■        |        |
| 96  | ■        |        |
| 116 | ■        |        |
| 136 | ■        |        |



2160 H



2170 H

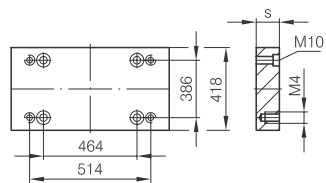
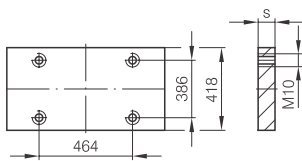

| S  | Material |        |
|----|----------|--------|
|    | 1.1730   | 1.2312 |
| 27 | ■        |        |

| S  | Material |        |
|----|----------|--------|
|    | 1.1730   | 1.2312 |
| 36 | ■        | ■      |

# 546 x 596

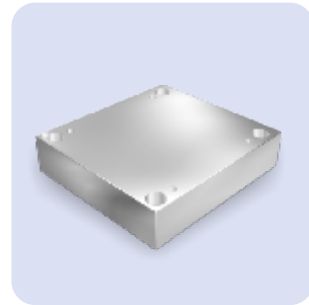
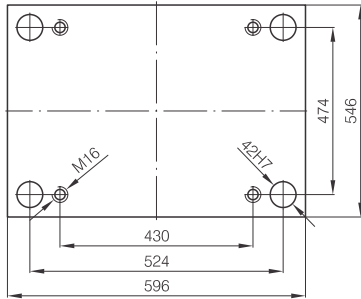

**2110 H**

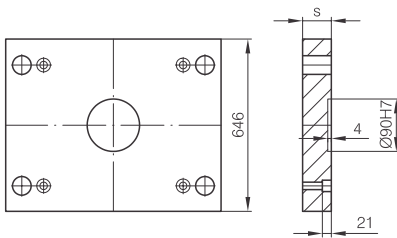

| S  | Material |        |
|----|----------|--------|
|    | 1.1730   | 1.2312 |
| 46 |          |        |
| 56 |          |        |



**2111 H**

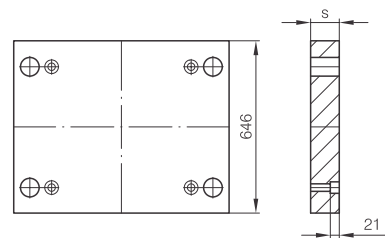

| S  | Material |        |
|----|----------|--------|
|    | 1.1730   | 1.2312 |
| 46 |          |        |
| 56 |          |        |



**2115 H**

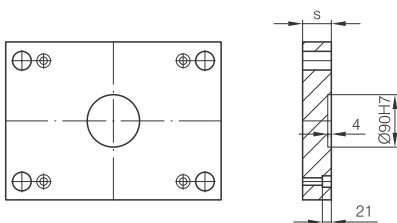

| S  | Material |        |
|----|----------|--------|
|    | 1.1730   | 1.2312 |
| 36 |          |        |
| 46 |          |        |



**2116 H**

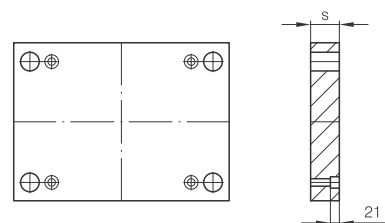

| S  | Material |        |        |
|----|----------|--------|--------|
|    | 1.1730   | 1.2162 | 1.2312 |
| 36 |          |        |        |
| 46 |          |        |        |



2120 H

2125 H

## 546 x 596

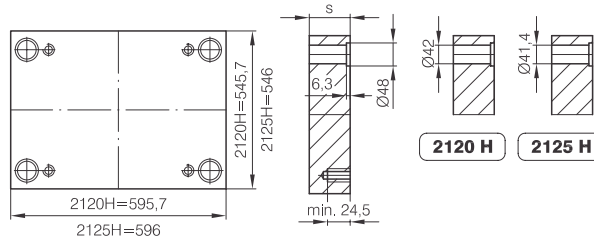

| S   | Material |        |        |        |        |        |        |        |
|-----|----------|--------|--------|--------|--------|--------|--------|--------|
|     | 1.1730   | 1.2162 | 1.2767 | 1.2083 | 1.2085 | 1.2311 | 1.2312 | 1.2343 |
| 36  | ■        |        |        |        | ■      |        | ■      |        |
| 46  | ■        |        |        |        | ■      | ■      | ■      |        |
| 56  | ■        |        |        |        | ■      | ■      | ■      |        |
| 66  | ■        |        |        |        | ■      |        | ■      |        |
| 76  | ■        |        |        |        | ■      | ■      | ■      | ■      |
| 86  | ■        |        |        |        | ■      |        | ■      |        |
| 96  | ■        |        |        |        | ■      | ■      | ■      | ■      |
| 116 | ■        |        |        |        | ■      | ■      | ■      | ■      |
| 136 | ■        |        |        |        | ■      | ■      | ■      | ■      |
| 156 | ■        |        |        |        | ■      | ■      | ■      | ■      |



2130 H



2140 H

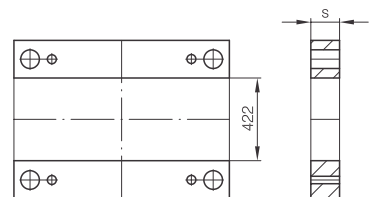
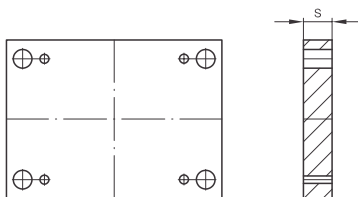

| S  | Material |        |
|----|----------|--------|
|    | 1.1730   | 1.2312 |
| 46 | ■        |        |
| 56 | ■        | ■      |

| S   | Material |        |
|-----|----------|--------|
|     | 1.1730   | 1.2312 |
| 76  | ■        |        |
| 86  | ■        |        |
| 96  | ■        |        |
| 116 | ■        |        |
| 136 | ■        |        |



2160 H



2170 H

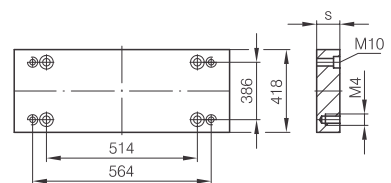
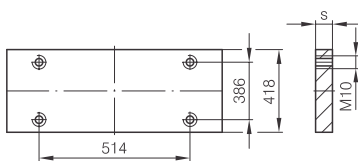

| S  | Material |        |
|----|----------|--------|
|    | 1.1730   | 1.2312 |
| 27 | ■        |        |

| S  | Material |        |
|----|----------|--------|
|    | 1.1730   | 1.2312 |
| 36 | ■        | ■      |

# 596 x 596

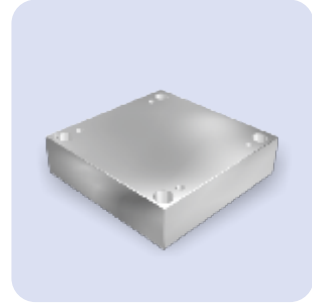
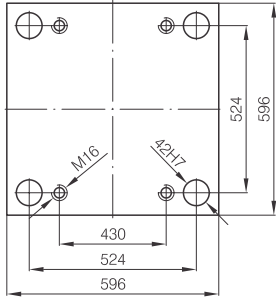

**2110 H**

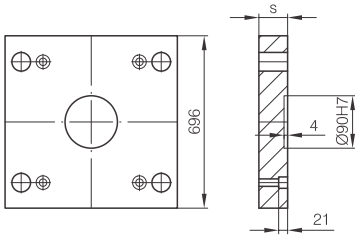

| S  | Material                 |                          |
|----|--------------------------|--------------------------|
|    | 1.1730                   | 1.2312                   |
| 46 | <input type="checkbox"/> | <input type="checkbox"/> |
| 56 | <input type="checkbox"/> | <input type="checkbox"/> |



**2111 H**

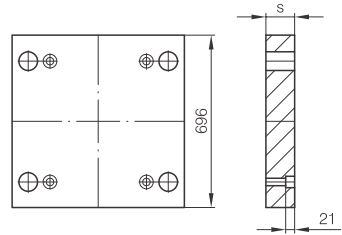

| S  | Material                 |                          |
|----|--------------------------|--------------------------|
|    | 1.1730                   | 1.2312                   |
| 46 | <input type="checkbox"/> | <input type="checkbox"/> |
| 56 | <input type="checkbox"/> | <input type="checkbox"/> |



**2115 H**

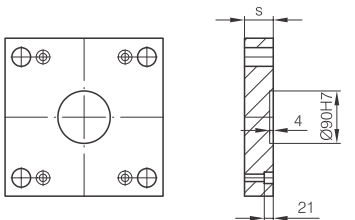

| S  | Material                 |                          |
|----|--------------------------|--------------------------|
|    | 1.1730                   | 1.2312                   |
| 36 | <input type="checkbox"/> | <input type="checkbox"/> |
| 46 | <input type="checkbox"/> | <input type="checkbox"/> |



**2116 H**

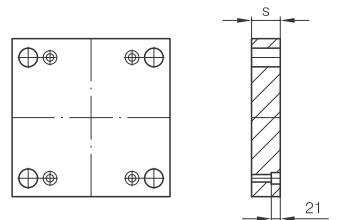

| S  | Material                 |                          |                          |
|----|--------------------------|--------------------------|--------------------------|
|    | 1.1730                   | 1.2162                   | 1.2312                   |
| 36 | <input type="checkbox"/> | <input type="checkbox"/> | <input type="checkbox"/> |
| 46 | <input type="checkbox"/> | <input type="checkbox"/> | <input type="checkbox"/> |



2120 H

2125 H

## 596 x 596

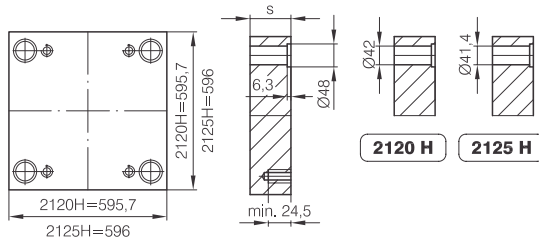

| S   | Material |        |        |        |        |        |        |        |
|-----|----------|--------|--------|--------|--------|--------|--------|--------|
|     | 1.1730   | 1.2162 | 1.2767 | 1.2083 | 1.2085 | 1.2311 | 1.2312 | 1.2343 |
| 36  | ■        |        |        |        | ■      |        | ■      |        |
| 46  | ■        |        |        |        | ■      | ■      | ■      |        |
| 56  | ■        |        |        |        | ■      | ■      | ■      |        |
| 66  | ■        |        |        |        | ■      | ■      | ■      |        |
| 76  | ■        |        |        |        | ■      | ■      | ■      | ■      |
| 86  | ■        |        |        |        | ■      | ■      | ■      |        |
| 96  | ■        |        |        |        | ■      | ■      | ■      | ■      |
| 116 | ■        |        |        |        | ■      | ■      | ■      | ■      |
| 136 | ■        |        |        |        | ■      | ■      | ■      | ■      |
| 156 | ■        |        |        |        | ■      | ■      | ■      | ■      |



2130 H



2140 H

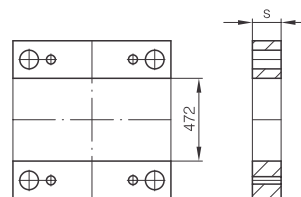
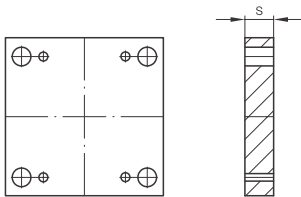

| S  | Material |        |
|----|----------|--------|
|    | 1.1730   | 1.2312 |
| 46 | ■        |        |
| 56 | ■        | ■      |

| S   | Material |        |
|-----|----------|--------|
|     | 1.1730   | 1.2312 |
| 76  | ■        |        |
| 86  | ■        |        |
| 96  | ■        |        |
| 116 | ■        |        |
| 136 | ■        |        |



2160 H



2170 H

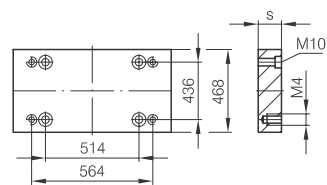
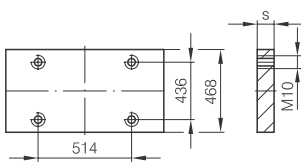

| S  | Material |        |
|----|----------|--------|
|    | 1.1730   | 1.2312 |
| 27 | ■        |        |

| S  | Material |        |
|----|----------|--------|
|    | 1.1730   | 1.2312 |
| 36 | ■        | ■      |

## 156 x 156

2190 H

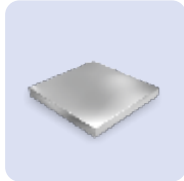
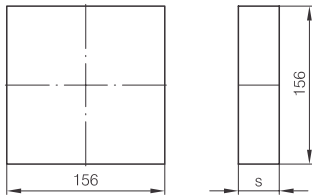

| S  | Material |        |        |        |        |        |        |        |
|----|----------|--------|--------|--------|--------|--------|--------|--------|
|    | 1.1730   | 1.2162 | 1.2767 | 1.2083 | 1.2085 | 1.2311 | 1.2312 | 1.2343 |
| 9  | ■        |        |        |        |        |        |        |        |
| 12 | ■        | ■      | ■      |        | ■      |        | ■      |        |
| 17 | ■        | ■      | ■      |        | ■      | ■      | ■      |        |
| 22 | ■        | ■      | ■      |        | ■      | ■      | ■      |        |
| 27 | ■        | ■      | ■      | ■      | ■      | ■      | ■      | ■      |
| 36 | ■        | ■      | ■      | ■      | ■      | ■      | ■      | ■      |
| 46 | ■        | ■      | ■      | ■      | ■      | ■      | ■      | ■      |
| 56 | ■        | ■      | ■      | ■      | ■      | ■      | ■      | ■      |
| 66 | ■        | ■      | ■      | ■      | ■      | ■      | ■      | ■      |
| 76 | ■        | ■      | ■      | ■      | ■      | ■      | ■      | ■      |

## 156 x 196

2190 H

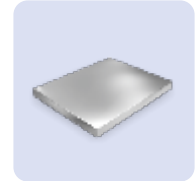
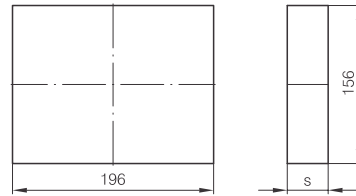

| S  | Material |        |        |        |        |        |        |        |
|----|----------|--------|--------|--------|--------|--------|--------|--------|
|    | 1.1730   | 1.2162 | 1.2767 | 1.2083 | 1.2085 | 1.2311 | 1.2312 | 1.2343 |
| 9  | ■        |        |        |        |        |        |        |        |
| 12 | ■        | ■      | ■      |        | ■      |        | ■      |        |
| 17 | ■        | ■      | ■      |        | ■      | ■      | ■      |        |
| 22 | ■        | ■      | ■      |        | ■      | ■      | ■      |        |
| 27 | ■        | ■      | ■      | ■      | ■      | ■      | ■      | ■      |
| 36 | ■        | ■      | ■      | ■      | ■      | ■      | ■      | ■      |
| 46 | ■        | ■      | ■      | ■      | ■      | ■      | ■      | ■      |
| 56 | ■        | ■      | ■      | ■      | ■      | ■      | ■      | ■      |
| 66 | ■        | ■      | ■      | ■      | ■      | ■      | ■      | ■      |
| 76 | ■        | ■      | ■      | ■      | ■      | ■      | ■      | ■      |

2191 H

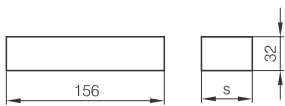

| S  | Material |        |
|----|----------|--------|
|    | 1.1730   | 1.2312 |
| 46 | ■        |        |
| 56 | ■        |        |
| 76 | ■        |        |
| 96 | ■        |        |

2191 H



| S  | Material |        |
|----|----------|--------|
|    | 1.1730   | 1.2312 |
| 46 | ■        |        |
| 56 | ■        |        |
| 76 | ■        |        |
| 96 | ■        |        |

2192 H

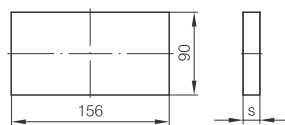

| S  | Material |        |
|----|----------|--------|
|    | 1.1730   | 1.2312 |
| 9  | ■        |        |
| 17 | ■        | ■      |

2192 H

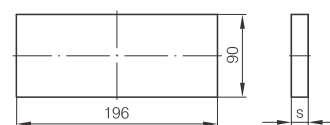

| S  | Material |        |
|----|----------|--------|
|    | 1.1730   | 1.2312 |
| 9  | ■        |        |
| 17 | ■        | ■      |

2193 H

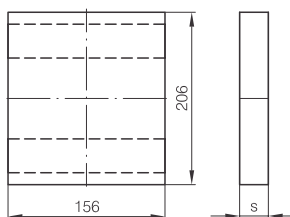

| S  | Material |        |
|----|----------|--------|
|    | 1.1730   | 1.2312 |
| 22 | ■        | ■      |
| 27 | ■        | ■      |
| 36 | ■        | ■      |

2193 H

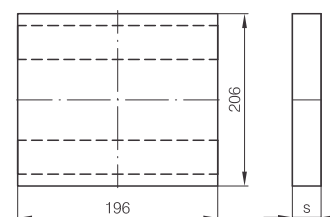

| S  | Material |        |
|----|----------|--------|
|    | 1.1730   | 1.2312 |
| 22 | ■        | ■      |
| 27 | ■        | ■      |
| 36 | ■        | ■      |

## 156 x 246

2190 H

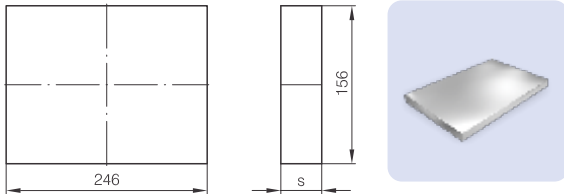

## 196 x 196

2190 H

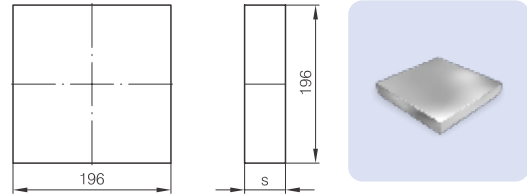

| S  | Material |        |        |        |        |        |        |        |
|----|----------|--------|--------|--------|--------|--------|--------|--------|
|    | 1.1730   | 1.2162 | 1.2767 | 1.2083 | 1.2085 | 1.2311 | 1.2312 | 1.2343 |
| 9  | ■        |        |        |        |        |        |        |        |
| 12 | ■        | ■      | ■      | ■      |        | ■      |        | ■      |
| 17 | ■        | ■      | ■      | ■      |        | ■      | ■      | ■      |
| 22 | ■        | ■      | ■      | ■      |        | ■      | ■      | ■      |
| 27 | ■        | ■      | ■      | ■      | ■      | ■      | ■      | ■      |
| 36 | ■        | ■      | ■      | ■      | ■      | ■      | ■      | ■      |
| 46 | ■        | ■      | ■      | ■      | ■      | ■      | ■      | ■      |
| 56 | ■        | ■      | ■      | ■      | ■      | ■      | ■      | ■      |
| 66 | ■        | ■      | ■      | ■      | ■      | ■      | ■      | ■      |
| 76 | ■        | ■      | ■      | ■      | ■      | ■      | ■      | ■      |
|    |          |        |        |        |        |        |        |        |

| S  | Material |        |        |        |        |        |        |        |
|----|----------|--------|--------|--------|--------|--------|--------|--------|
|    | 1.1730   | 1.2162 | 1.2767 | 1.2083 | 1.2085 | 1.2311 | 1.2312 | 1.2343 |
| 12 | ■        |        |        |        |        |        |        |        |
| 17 | ■        | ■      | ■      |        | ■      | ■      | ■      |        |
| 22 | ■        | ■      | ■      |        | ■      | ■      | ■      |        |
| 27 | ■        | ■      | ■      | ■      | ■      | ■      | ■      | ■      |
| 36 | ■        | ■      | ■      | ■      | ■      | ■      | ■      | ■      |
| 46 | ■        | ■      | ■      | ■      | ■      | ■      | ■      | ■      |
| 56 | ■        | ■      | ■      | ■      | ■      | ■      | ■      | ■      |
| 66 | ■        | ■      | ■      | ■      | ■      | ■      | ■      | ■      |
| 76 | ■        | ■      | ■      | ■      | ■      | ■      | ■      | ■      |
| 86 | ■        | ■      | ■      | ■      | ■      | ■      | ■      | ■      |
| 96 | ■        | ■      | ■      | ■      | ■      | ■      | ■      | ■      |

2191 H

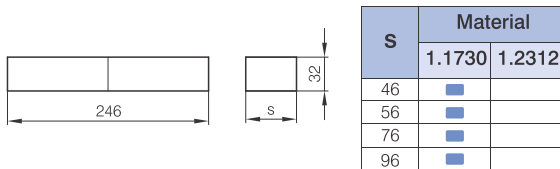

| S  | Material |        |
|----|----------|--------|
|    | 1.1730   | 1.2312 |
| 46 | ■        |        |
| 56 | ■        |        |
| 76 | ■        |        |
| 96 | ■        |        |

2191 H

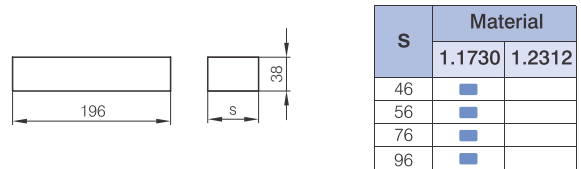

| S  | Material |        |
|----|----------|--------|
|    | 1.1730   | 1.2312 |
| 46 | ■        |        |
| 56 | ■        |        |
| 76 | ■        |        |
| 96 | ■        |        |

2192 H

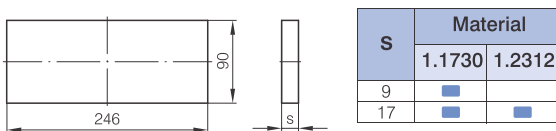

| S  | Material |        |
|----|----------|--------|
|    | 1.1730   | 1.2312 |
| 9  | ■        |        |
| 17 | ■        | ■      |

2192 H

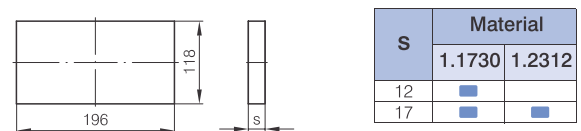

| S  | Material |        |
|----|----------|--------|
|    | 1.1730   | 1.2312 |
| 12 | ■        |        |
| 17 | ■        | ■      |

2193 H

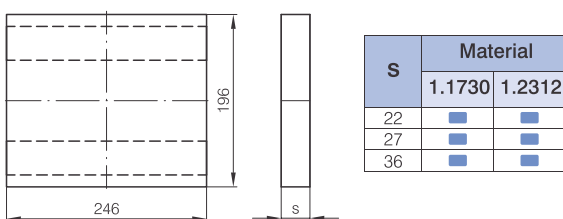

| S  | Material |        |
|----|----------|--------|
|    | 1.1730   | 1.2312 |
| 22 | ■        | ■      |
| 27 | ■        | ■      |
| 36 | ■        | ■      |

2193 H

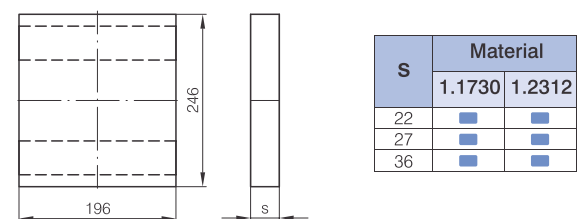

| S  | Material |        |
|----|----------|--------|
|    | 1.1730   | 1.2312 |
| 22 | ■        | ■      |
| 27 | ■        | ■      |
| 36 | ■        | ■      |

## 190 x 246

### 2190 H

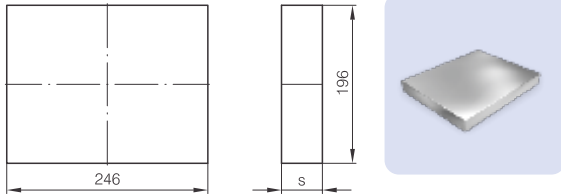

| S  | Material |        |        |        |        |        |        |        |
|----|----------|--------|--------|--------|--------|--------|--------|--------|
|    | 1.1730   | 1.2162 | 1.2767 | 1.2083 | 1.2085 | 1.2311 | 1.2312 | 1.2343 |
| 12 | ■        |        |        |        |        |        |        |        |
| 17 | ■        | ■      | ■      |        | ■      | ■      | ■      |        |
| 22 | ■        | ■      | ■      |        | ■      | ■      | ■      |        |
| 27 | ■        | ■      | ■      | ■      | ■      | ■      | ■      | ■      |
| 36 | ■        | ■      | ■      | ■      | ■      | ■      | ■      | ■      |
| 46 | ■        | ■      | ■      | ■      | ■      | ■      | ■      | ■      |
| 56 | ■        | ■      | ■      | ■      | ■      | ■      | ■      | ■      |
| 66 | ■        | ■      | ■      | ■      | ■      | ■      | ■      | ■      |
| 76 | ■        | ■      | ■      | ■      | ■      | ■      | ■      | ■      |
| 86 | ■        | ■      | ■      | ■      | ■      | ■      | ■      | ■      |
| 96 | ■        | ■      | ■      | ■      | ■      | ■      | ■      | ■      |

## 196 x 296

### 2190 H

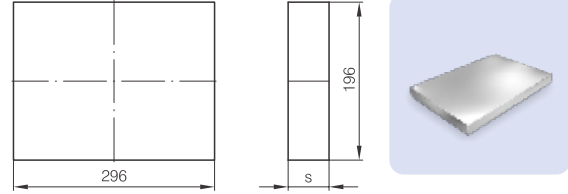

| S  | Material |        |        |        |        |        |        |        |
|----|----------|--------|--------|--------|--------|--------|--------|--------|
|    | 1.1730   | 1.2162 | 1.2767 | 1.2083 | 1.2085 | 1.2311 | 1.2312 | 1.2343 |
| 12 | ■        |        |        |        |        |        |        |        |
| 17 | ■        | ■      | ■      |        | ■      | ■      | ■      |        |
| 22 | ■        | ■      | ■      |        | ■      | ■      | ■      |        |
| 27 | ■        | ■      | ■      | ■      | ■      | ■      | ■      | ■      |
| 36 | ■        | ■      | ■      | ■      | ■      | ■      | ■      | ■      |
| 46 | ■        | ■      | ■      | ■      | ■      | ■      | ■      | ■      |
| 56 | ■        | ■      | ■      | ■      | ■      | ■      | ■      | ■      |
| 66 | ■        | ■      | ■      | ■      | ■      | ■      | ■      | ■      |
| 76 | ■        | ■      | ■      | ■      | ■      | ■      | ■      | ■      |
| 86 | ■        | ■      | ■      | ■      | ■      | ■      | ■      | ■      |
| 96 | ■        | ■      | ■      | ■      | ■      | ■      | ■      | ■      |

### 2191 H

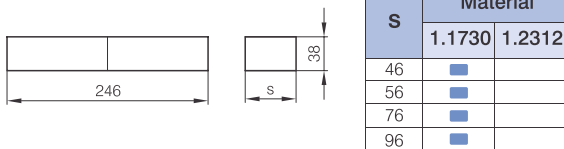

| S  | Material |        |
|----|----------|--------|
|    | 1.1730   | 1.2312 |
| 46 | ■        |        |
| 56 | ■        |        |
| 76 | ■        |        |
| 96 | ■        |        |

### 2191 H

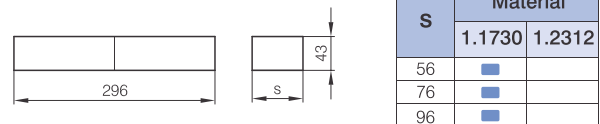

| S  | Material |        |
|----|----------|--------|
|    | 1.1730   | 1.2312 |
| 56 | ■        |        |
| 76 | ■        |        |
| 96 | ■        |        |

### 2192 H

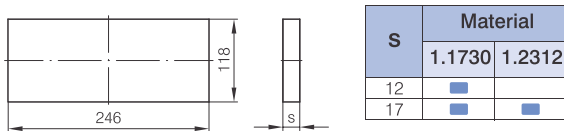

| S  | Material |        |
|----|----------|--------|
|    | 1.1730   | 1.2312 |
| 12 | ■        |        |
| 17 | ■        | ■      |

### 2192 H

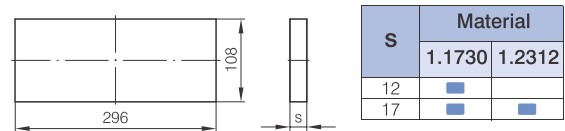

| S  | Material |        |
|----|----------|--------|
|    | 1.1730   | 1.2312 |
| 12 | ■        |        |
| 17 | ■        | ■      |

### 2193 H

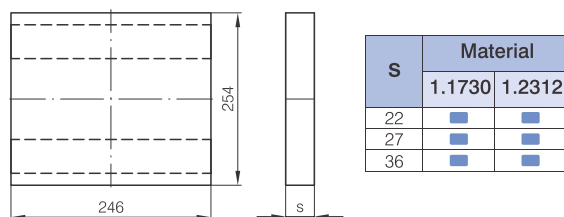

| S  | Material |        |
|----|----------|--------|
|    | 1.1730   | 1.2312 |
| 22 | ■        | ■      |
| 27 | ■        | ■      |
| 36 | ■        | ■      |

### 2193 H

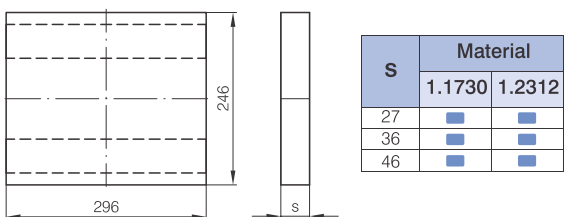

| S  | Material |        |
|----|----------|--------|
|    | 1.1730   | 1.2312 |
| 27 | ■        | ■      |
| 36 | ■        | ■      |
| 46 | ■        | ■      |

## 246 x 246

2190 H

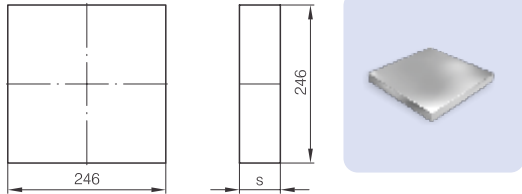

| S  | Material |        |        |        |        |        |        |        |
|----|----------|--------|--------|--------|--------|--------|--------|--------|
|    | 1.1730   | 1.2162 | 1.2767 | 1.2083 | 1.2085 | 1.2311 | 1.2312 | 1.2343 |
| 12 | ■        |        |        |        |        |        |        |        |
| 17 | ■        | ■      | ■      |        | ■      | ■      | ■      |        |
| 22 | ■        | ■      | ■      |        | ■      | ■      | ■      |        |
| 27 | ■        | ■      | ■      | ■      | ■      | ■      | ■      | ■      |
| 36 | ■        | ■      | ■      | ■      | ■      | ■      | ■      | ■      |
| 46 | ■        | ■      | ■      | ■      | ■      | ■      | ■      | ■      |
| 56 | ■        | ■      | ■      | ■      | ■      | ■      | ■      | ■      |
| 66 | ■        | ■      | ■      | ■      | ■      | ■      | ■      | ■      |
| 76 | ■        | ■      | ■      | ■      | ■      | ■      | ■      | ■      |
| 86 | ■        | ■      | ■      | ■      | ■      | ■      | ■      | ■      |
| 96 | ■        | ■      | ■      | ■      | ■      | ■      | ■      | ■      |

## 246 x 296

2190 H

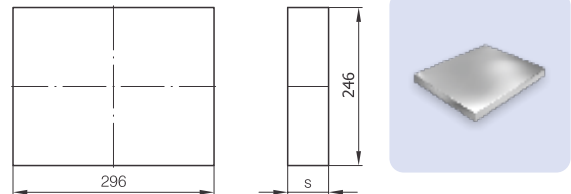

| S   | Material |        |        |        |        |        |        |        |
|-----|----------|--------|--------|--------|--------|--------|--------|--------|
|     | 1.1730   | 1.2162 | 1.2767 | 1.2083 | 1.2085 | 1.2311 | 1.2312 | 1.2343 |
| 12  | ■        |        |        |        |        |        |        |        |
| 17  | ■        | ■      | ■      |        | ■      | ■      | ■      |        |
| 22  | ■        | ■      | ■      |        | ■      | ■      | ■      |        |
| 27  | ■        | ■      | ■      |        | ■      | ■      | ■      |        |
| 36  | ■        | ■      | ■      | ■      | ■      | ■      | ■      | ■      |
| 46  | ■        | ■      | ■      | ■      | ■      | ■      | ■      | ■      |
| 56  | ■        | ■      | ■      | ■      | ■      | ■      | ■      | ■      |
| 66  | ■        | ■      | ■      | ■      | ■      | ■      | ■      | ■      |
| 76  | ■        | ■      | ■      | ■      | ■      | ■      | ■      | ■      |
| 86  | ■        | ■      | ■      | ■      | ■      | ■      | ■      | ■      |
| 96  | ■        | ■      | ■      | ■      | ■      | ■      | ■      | ■      |
| 116 | ■        | ■      | ■      | ■      | ■      | ■      | ■      | ■      |

2191 H

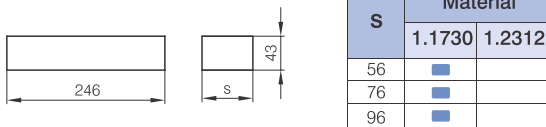

| S  | Material |        |
|----|----------|--------|
|    | 1.1730   | 1.2312 |
| 56 | ■        |        |
| 76 | ■        |        |
| 96 | ■        |        |

2191 H

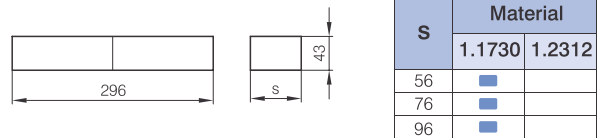

| S  | Material |        |
|----|----------|--------|
|    | 1.1730   | 1.2312 |
| 56 | ■        |        |
| 76 | ■        |        |
| 96 | ■        |        |

2192 H

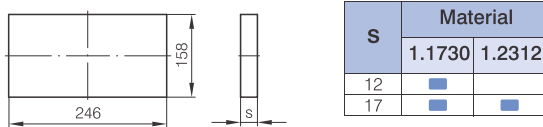

| S  | Material |        |
|----|----------|--------|
|    | 1.1730   | 1.2312 |
| 12 | ■        |        |
| 17 | ■        | ■      |

2192 H

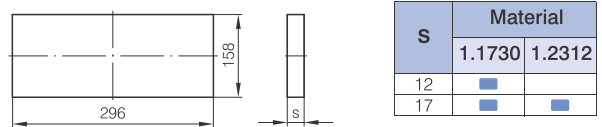

| S  | Material |        |
|----|----------|--------|
|    | 1.1730   | 1.2312 |
| 12 | ■        |        |
| 17 | ■        | ■      |

2193 H

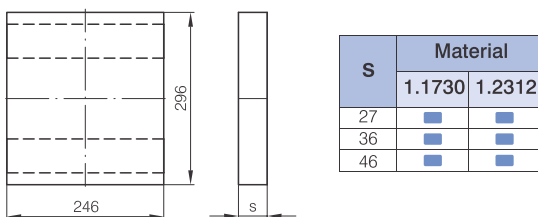

| S  | Material |        |
|----|----------|--------|
|    | 1.1730   | 1.2312 |
| 27 | ■        | ■      |
| 36 | ■        | ■      |
| 46 | ■        | ■      |

2193 H

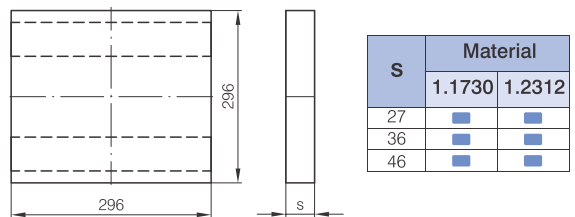

| S  | Material |        |
|----|----------|--------|
|    | 1.1730   | 1.2312 |
| 27 | ■        | ■      |
| 36 | ■        | ■      |
| 46 | ■        | ■      |

## 246 x 346

2190 H

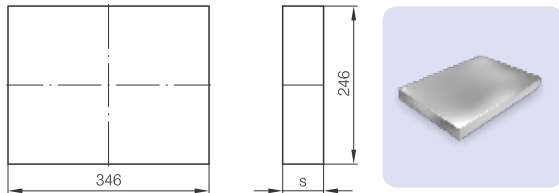

## 246 x 396

2190 H

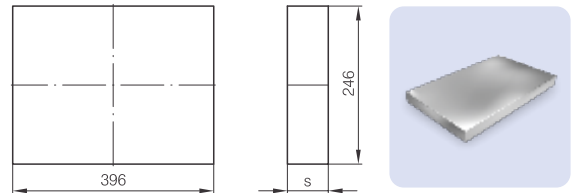

| S   | Material |        |        |        |        |        |        |        |
|-----|----------|--------|--------|--------|--------|--------|--------|--------|
|     | 1.1730   | 1.2162 | 1.2767 | 1.2083 | 1.2085 | 1.2311 | 1.2312 | 1.2343 |
| 17  | ■        | ■      | ■      |        | ■      | ■      | ■      |        |
| 22  | ■        | ■      | ■      |        | ■      | ■      | ■      |        |
| 27  | ■        | ■      | ■      |        | ■      | ■      | ■      |        |
| 36  | ■        | ■      | ■      | ■      | ■      | ■      | ■      | ■      |
| 46  | ■        | ■      | ■      | ■      | ■      | ■      | ■      | ■      |
| 56  | ■        | ■      | ■      | ■      | ■      | ■      | ■      | ■      |
| 66  | ■        | ■      | ■      | ■      | ■      | ■      | ■      | ■      |
| 76  | ■        | ■      | ■      | ■      | ■      | ■      | ■      | ■      |
| 86  | ■        | ■      | ■      | ■      | ■      | ■      | ■      | ■      |
| 96  | ■        | ■      | ■      | ■      | ■      | ■      | ■      | ■      |
| 116 | ■        | ■      | ■      | ■      | ■      | ■      | ■      | ■      |

| S   | Material |        |        |        |        |        |        |        |
|-----|----------|--------|--------|--------|--------|--------|--------|--------|
|     | 1.1730   | 1.2162 | 1.2767 | 1.2083 | 1.2085 | 1.2311 | 1.2312 | 1.2343 |
| 17  | ■        | ■      | ■      |        | ■      | ■      | ■      |        |
| 22  | ■        | ■      | ■      |        | ■      | ■      | ■      |        |
| 27  | ■        | ■      | ■      |        | ■      | ■      | ■      |        |
| 36  | ■        | ■      | ■      | ■      | ■      | ■      | ■      | ■      |
| 46  | ■        | ■      | ■      | ■      | ■      | ■      | ■      | ■      |
| 56  | ■        | ■      | ■      | ■      | ■      | ■      | ■      | ■      |
| 66  | ■        | ■      | ■      | ■      | ■      | ■      | ■      | ■      |
| 76  | ■        | ■      | ■      | ■      | ■      | ■      | ■      | ■      |
| 86  | ■        | ■      | ■      | ■      | ■      | ■      | ■      | ■      |
| 96  | ■        | ■      | ■      | ■      | ■      | ■      | ■      | ■      |
| 116 | ■        | ■      | ■      | ■      | ■      | ■      | ■      | ■      |

2191 H

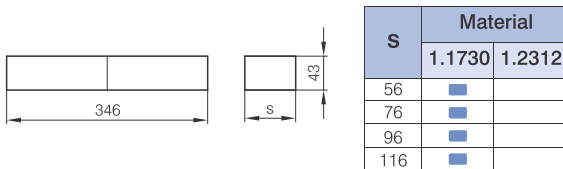

| S   | Material |        |
|-----|----------|--------|
|     | 1.1730   | 1.2312 |
| 56  | ■        |        |
| 76  | ■        |        |
| 96  | ■        |        |
| 116 | ■        |        |

2191 H

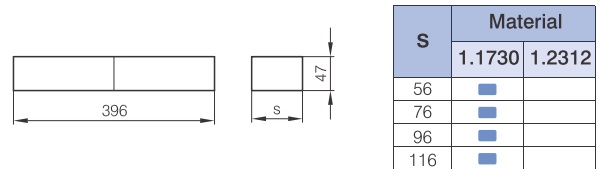

| S   | Material |        |
|-----|----------|--------|
|     | 1.1730   | 1.2312 |
| 56  | ■        |        |
| 76  | ■        |        |
| 96  | ■        |        |
| 116 | ■        |        |

2192 H

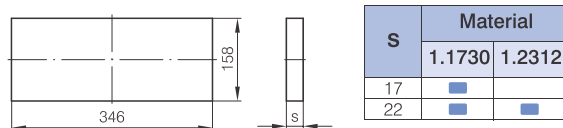

| S  | Material |        |
|----|----------|--------|
|    | 1.1730   | 1.2312 |
| 17 | ■        |        |
| 22 | ■        | ■      |

2192 H

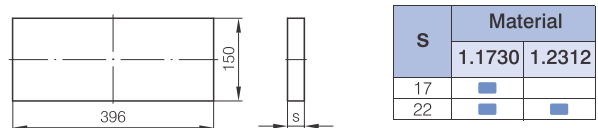

| S  | Material |        |
|----|----------|--------|
|    | 1.1730   | 1.2312 |
| 17 | ■        |        |
| 22 | ■        | ■      |

2193 H

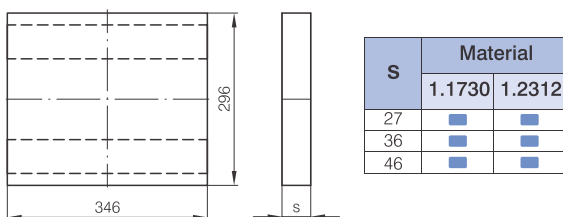

| S  | Material |        |
|----|----------|--------|
|    | 1.1730   | 1.2312 |
| 27 | ■        | ■      |
| 36 | ■        | ■      |
| 46 | ■        | ■      |

2193 H

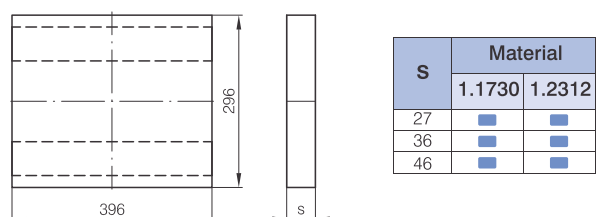

| S  | Material |        |
|----|----------|--------|
|    | 1.1730   | 1.2312 |
| 27 | ■        | ■      |
| 36 | ■        | ■      |
| 46 | ■        | ■      |

## 296 x 296

### 2190 H

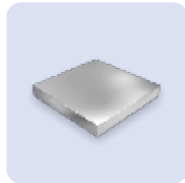
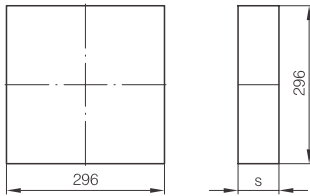

## 296 x 346

### 2190 H

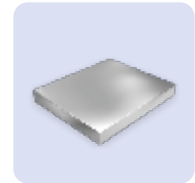
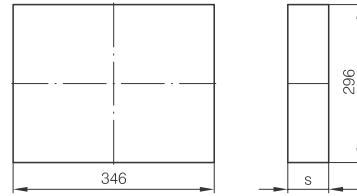

| S   | Material |        |        |        |        |        |        |        |
|-----|----------|--------|--------|--------|--------|--------|--------|--------|
|     | 1.1730   | 1.2162 | 1.2767 | 1.2083 | 1.2085 | 1.2311 | 1.2312 | 1.2343 |
| 12  | ■        |        |        |        |        |        |        |        |
| 17  | ■        |        |        |        |        |        |        |        |
| 22  | ■        | ■      | ■      |        | ■      | ■      | ■      |        |
| 27  | ■        | ■      | ■      |        | ■      | ■      | ■      |        |
| 36  | ■        | ■      | ■      | ■      | ■      | ■      | ■      | ■      |
| 46  | ■        | ■      | ■      | ■      | ■      | ■      | ■      | ■      |
| 56  | ■        | ■      | ■      | ■      | ■      | ■      | ■      | ■      |
| 66  | ■        | ■      | ■      | ■      | ■      | ■      | ■      | ■      |
| 76  | ■        | ■      | ■      | ■      | ■      | ■      | ■      | ■      |
| 86  | ■        | ■      | ■      | ■      | ■      | ■      | ■      | ■      |
| 96  | ■        | ■      | ■      | ■      | ■      | ■      | ■      | ■      |
| 116 | ■        | ■      | ■      | ■      | ■      | ■      | ■      | ■      |

| S   | Material |        |        |        |        |        |        |        |
|-----|----------|--------|--------|--------|--------|--------|--------|--------|
|     | 1.1730   | 1.2162 | 1.2767 | 1.2083 | 1.2085 | 1.2311 | 1.2312 | 1.2343 |
| 17  | ■        |        |        |        |        |        |        |        |
| 22  | ■        | ■      | ■      |        | ■      | ■      | ■      |        |
| 27  | ■        | ■      | ■      |        | ■      | ■      | ■      |        |
| 36  | ■        | ■      | ■      | ■      | ■      | ■      | ■      | ■      |
| 46  | ■        | ■      | ■      | ■      | ■      | ■      | ■      | ■      |
| 56  | ■        | ■      | ■      | ■      | ■      | ■      | ■      | ■      |
| 66  | ■        | ■      | ■      | ■      | ■      | ■      | ■      | ■      |
| 76  | ■        | ■      | ■      | ■      | ■      | ■      | ■      | ■      |
| 86  | ■        | ■      | ■      | ■      | ■      | ■      | ■      | ■      |
| 96  | ■        | ■      | ■      | ■      | ■      | ■      | ■      | ■      |
| 116 | ■        | ■      | ■      | ■      | ■      | ■      | ■      | ■      |

### 2191 H



| S  | Material |        |
|----|----------|--------|
|    | 1.1730   | 1.2312 |
| 56 | ■        |        |
| 76 | ■        |        |
| 96 | ■        |        |

### 2191 H



| S   | Material |        |
|-----|----------|--------|
|     | 1.1730   | 1.2312 |
| 56  | ■        |        |
| 76  | ■        |        |
| 96  | ■        |        |
| 116 | ■        |        |

### 2192 H

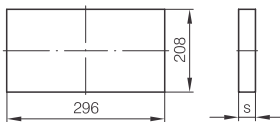

| S  | Material |        |
|----|----------|--------|
|    | 1.1730   | 1.2312 |
| 12 | ■        |        |
| 17 | ■        | ■      |

### 2192 H

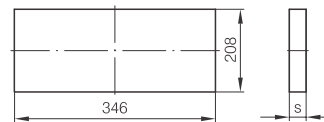

| S  | Material |        |
|----|----------|--------|
|    | 1.1730   | 1.2312 |
| 17 | ■        |        |
| 22 | ■        | ■      |

### 2193 H

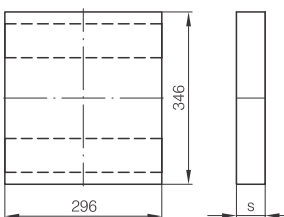

| S  | Material |        |
|----|----------|--------|
|    | 1.1730   | 1.2312 |
| 27 | ■        | ■      |
| 36 | ■        | ■      |
| 46 | ■        | ■      |

### 2193 H

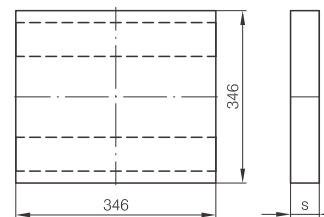

| S  | Material |        |
|----|----------|--------|
|    | 1.1730   | 1.2312 |
| 27 | ■        | ■      |
| 36 | ■        | ■      |
| 46 | ■        | ■      |

## 296 x 396

### 2190 H

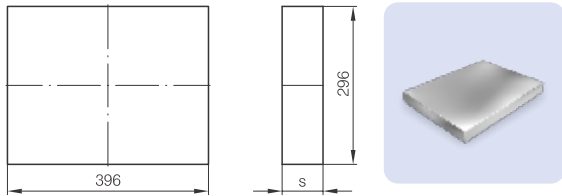

| S   | Material |        |        |        |        |        |        |        |
|-----|----------|--------|--------|--------|--------|--------|--------|--------|
|     | 1.1730   | 1.2162 | 1.2767 | 1.2083 | 1.2085 | 1.2311 | 1.2312 | 1.2343 |
| 17  | ■        |        |        |        |        |        |        |        |
| 22  | ■        | ■      | ■      |        | ■      | ■      | ■      |        |
| 27  | ■        | ■      | ■      |        | ■      | ■      | ■      |        |
| 36  | ■        | ■      | ■      | ■      | ■      | ■      | ■      | ■      |
| 46  | ■        | ■      | ■      | ■      | ■      | ■      | ■      | ■      |
| 56  | ■        | ■      | ■      | ■      | ■      | ■      | ■      | ■      |
| 66  | ■        | ■      | ■      | ■      | ■      | ■      | ■      | ■      |
| 76  | ■        | ■      | ■      | ■      | ■      | ■      | ■      | ■      |
| 86  | ■        | ■      | ■      | ■      | ■      | ■      | ■      | ■      |
| 96  | ■        | ■      | ■      | ■      | ■      | ■      | ■      | ■      |
| 116 | ■        | ■      | ■      | ■      | ■      | ■      | ■      | ■      |

## 296 x 446

### 2190 H

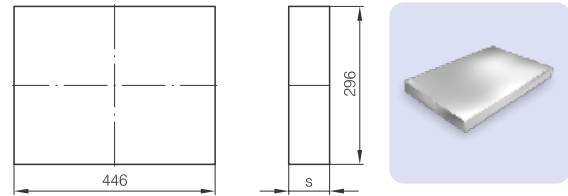

| S   | Material |        |        |        |        |        |        |        |
|-----|----------|--------|--------|--------|--------|--------|--------|--------|
|     | 1.1730   | 1.2162 | 1.2767 | 1.2083 | 1.2085 | 1.2311 | 1.2312 | 1.2343 |
| 27  | ■        | ■      |        |        | ■      | ■      | ■      |        |
| 36  | ■        | ■      |        |        | ■      | ■      | ■      |        |
| 46  | ■        | ■      |        |        | ■      | ■      | ■      |        |
| 56  | ■        | ■      |        |        | ■      | ■      | ■      |        |
| 66  | ■        | ■      |        |        | ■      | ■      | ■      |        |
| 76  | ■        | ■      |        |        | ■      | ■      | ■      |        |
| 86  | ■        | ■      |        |        | ■      | ■      | ■      |        |
| 96  | ■        | ■      |        |        | ■      | ■      | ■      |        |
| 116 | ■        | ■      |        |        | ■      | ■      | ■      |        |

### 2191 H

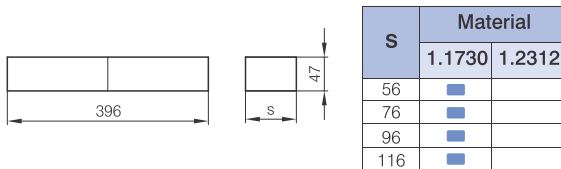

| S   | Material |        |
|-----|----------|--------|
|     | 1.1730   | 1.2312 |
| 56  | ■        |        |
| 76  | ■        |        |
| 96  | ■        |        |
| 116 | ■        |        |

### 2191 H

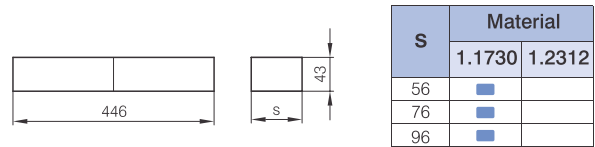

| S  | Material |        |
|----|----------|--------|
|    | 1.1730   | 1.2312 |
| 56 | ■        |        |
| 76 | ■        |        |
| 96 | ■        |        |

### 2192 H

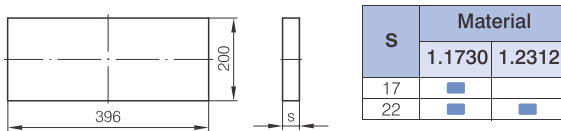

| S  | Material |        |
|----|----------|--------|
|    | 1.1730   | 1.2312 |
| 17 | ■        |        |
| 22 | ■        | ■      |

### 2192 H

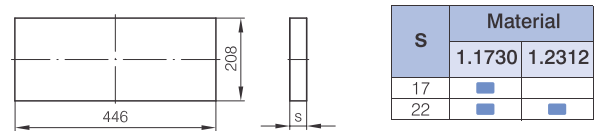

| S  | Material |        |
|----|----------|--------|
|    | 1.1730   | 1.2312 |
| 17 | ■        |        |
| 22 | ■        | ■      |

### 2193 H

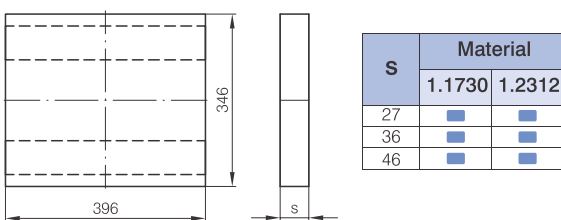

| S  | Material |        |
|----|----------|--------|
|    | 1.1730   | 1.2312 |
| 27 | ■        | ■      |
| 36 | ■        | ■      |
| 46 | ■        | ■      |

### 2193 H

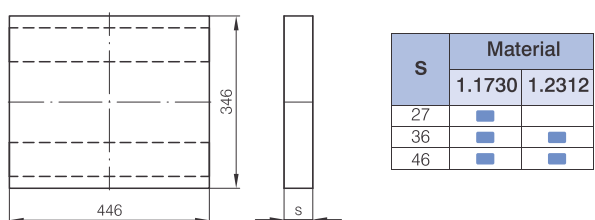

| S  | Material |        |
|----|----------|--------|
|    | 1.1730   | 1.2312 |
| 27 | ■        | ■      |
| 36 | ■        | ■      |
| 46 | ■        | ■      |

# 346 x 346

## 2190 H

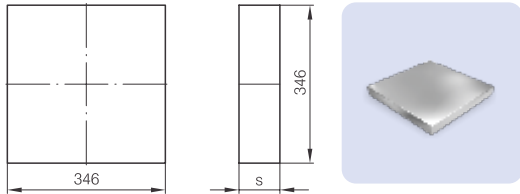

| S   | Material |        |        |        |        |        |        |        |
|-----|----------|--------|--------|--------|--------|--------|--------|--------|
|     | 1.1730   | 1.2162 | 1.2767 | 1.2083 | 1.2085 | 1.2311 | 1.2312 | 1.2343 |
| 17  | ■        |        |        |        |        |        |        |        |
| 22  | ■        | ■      | ■      |        | ■      | ■      | ■      |        |
| 27  | ■        | ■      | ■      |        | ■      | ■      | ■      |        |
| 36  | ■        | ■      | ■      | ■      | ■      | ■      | ■      | ■      |
| 46  | ■        | ■      | ■      | ■      | ■      | ■      | ■      | ■      |
| 56  | ■        | ■      | ■      | ■      | ■      | ■      | ■      | ■      |
| 66  | ■        | ■      | ■      | ■      | ■      | ■      | ■      | ■      |
| 76  | ■        | ■      | ■      | ■      | ■      | ■      | ■      | ■      |
| 86  | ■        | ■      | ■      | ■      | ■      | ■      | ■      | ■      |
| 96  | ■        | ■      | ■      | ■      | ■      | ■      | ■      | ■      |
| 116 | ■        | ■      | ■      | ■      | ■      | ■      | ■      | ■      |

# 346 x 396

## 2190 H

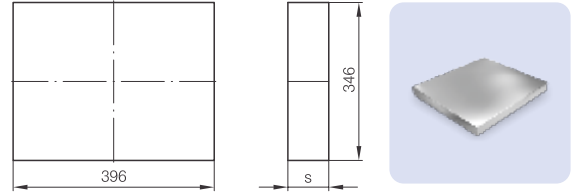

| S   | Material |        |        |        |        |        |        |        |
|-----|----------|--------|--------|--------|--------|--------|--------|--------|
|     | 1.1730   | 1.2162 | 1.2767 | 1.2083 | 1.2085 | 1.2311 | 1.2312 | 1.2343 |
| 17  | ■        |        |        |        |        |        |        |        |
| 22  | ■        | ■      | ■      |        | ■      |        | ■      |        |
| 27  | ■        | ■      | ■      |        | ■      | ■      | ■      |        |
| 36  | ■        | ■      | ■      |        | ■      | ■      | ■      |        |
| 46  | ■        | ■      | ■      | ■      | ■      | ■      | ■      | ■      |
| 56  | ■        | ■      | ■      | ■      | ■      | ■      | ■      | ■      |
| 66  | ■        | ■      | ■      | ■      | ■      | ■      | ■      | ■      |
| 76  | ■        | ■      | ■      | ■      | ■      | ■      | ■      | ■      |
| 86  | ■        | ■      | ■      | ■      | ■      | ■      | ■      | ■      |
| 96  | ■        | ■      | ■      | ■      | ■      | ■      | ■      | ■      |
| 116 | ■        | ■      | ■      | ■      | ■      | ■      | ■      | ■      |

## 2191 H

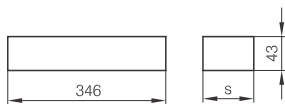

| S   | Material |        |
|-----|----------|--------|
|     | 1.1730   | 1.2312 |
| 56  | ■        |        |
| 76  | ■        |        |
| 96  | ■        |        |
| 116 | ■        |        |

## 2191 H



| S   | Material |        |
|-----|----------|--------|
|     | 1.1730   | 1.2312 |
| 56  | ■        |        |
| 66  | ■        |        |
| 76  | ■        |        |
| 86  | ■        |        |
| 96  | ■        |        |
| 116 | ■        |        |

## 2192 H

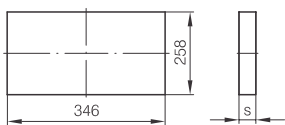

| S  | Material |        |
|----|----------|--------|
|    | 1.1730   | 1.2312 |
| 17 | ■        |        |
| 22 | ■        | ■      |

## 2192 H

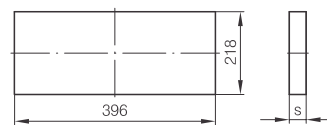

| S  | Material |        |
|----|----------|--------|
|    | 1.1730   | 1.2312 |
| 17 | ■        |        |
| 22 | ■        | ■      |

## 2193 H

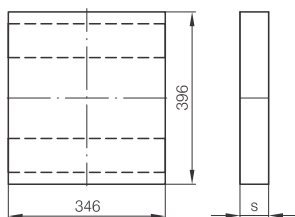

| S  | Material |        |
|----|----------|--------|
|    | 1.1730   | 1.2312 |
| 27 | ■        | ■      |
| 36 | ■        | ■      |
| 46 | ■        | ■      |

## 2193 H

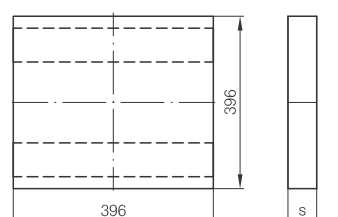

| S  | Material |        |
|----|----------|--------|
|    | 1.1730   | 1.2312 |
| 27 | ■        | ■      |
| 36 | ■        | ■      |
| 46 | ■        | ■      |

## 346 x 446

2190 H

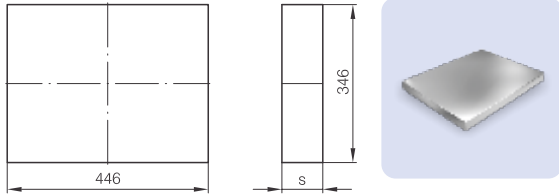

## 346 x 496

2190 H

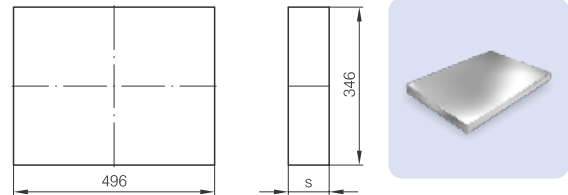

| S   | Material |        |        |        |        |        |        |        |
|-----|----------|--------|--------|--------|--------|--------|--------|--------|
|     | 1.1730   | 1.2162 | 1.2767 | 1.2083 | 1.2085 | 1.2311 | 1.2312 | 1.2343 |
| 17  | ■        |        |        |        |        |        |        |        |
| 22  | ■        |        |        |        | ■      |        | ■      |        |
| 27  | ■        |        |        |        | ■      |        | ■      |        |
| 36  | ■        | ■      |        |        | ■      | ■      | ■      |        |
| 46  | ■        | ■      |        |        | ■      | ■      | ■      |        |
| 56  | ■        | ■      |        | ■      | ■      | ■      | ■      | ■      |
| 66  | ■        |        |        |        | ■      |        | ■      |        |
| 76  | ■        | ■      |        | ■      | ■      | ■      | ■      | ■      |
| 86  | ■        |        |        |        | ■      |        | ■      |        |
| 96  | ■        | ■      |        | ■      | ■      | ■      | ■      | ■      |
| 116 | ■        | ■      |        | ■      | ■      | ■      | ■      | ■      |

| S   | Material |        |        |        |        |        |        |        |
|-----|----------|--------|--------|--------|--------|--------|--------|--------|
|     | 1.1730   | 1.2162 | 1.2767 | 1.2083 | 1.2085 | 1.2311 | 1.2312 | 1.2343 |
| 17  | ■        |        |        |        |        |        |        |        |
| 22  | ■        | ■      | ■      |        | ■      |        | ■      |        |
| 27  | ■        | ■      | ■      |        | ■      | ■      | ■      |        |
| 36  | ■        | ■      | ■      |        | ■      | ■      | ■      |        |
| 46  | ■        | ■      | ■      | ■      | ■      | ■      | ■      | ■      |
| 56  | ■        | ■      | ■      | ■      | ■      | ■      | ■      | ■      |
| 66  | ■        |        |        |        | ■      |        | ■      |        |
| 76  | ■        | ■      | ■      | ■      | ■      | ■      | ■      | ■      |
| 86  | ■        |        |        | ■      | ■      |        | ■      |        |
| 96  | ■        | ■      | ■      | ■      | ■      | ■      | ■      | ■      |
| 116 | ■        | ■      | ■      | ■      | ■      | ■      | ■      | ■      |

2191 H

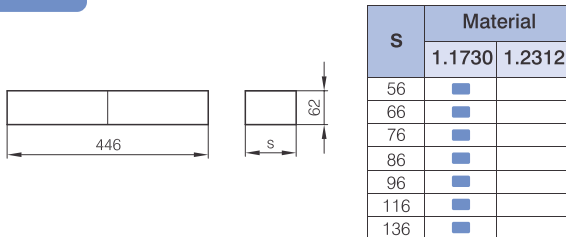

| S   | Material |        |
|-----|----------|--------|
|     | 1.1730   | 1.2312 |
| 56  | ■        |        |
| 66  | ■        |        |
| 76  | ■        |        |
| 86  | ■        |        |
| 96  | ■        |        |
| 116 | ■        |        |
| 136 | ■        |        |

2191 H

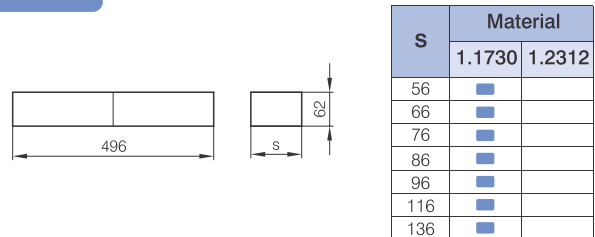

| S   | Material |        |
|-----|----------|--------|
|     | 1.1730   | 1.2312 |
| 56  | ■        |        |
| 66  | ■        |        |
| 76  | ■        |        |
| 86  | ■        |        |
| 96  | ■        |        |
| 116 | ■        |        |
| 136 | ■        |        |

2192 H

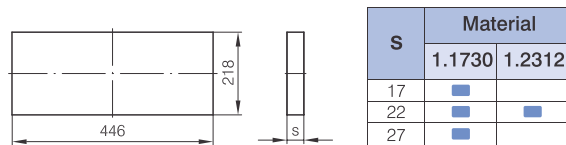

| S  | Material |        |
|----|----------|--------|
|    | 1.1730   | 1.2312 |
| 17 | ■        |        |
| 22 | ■        | ■      |
| 27 | ■        |        |

2192 H

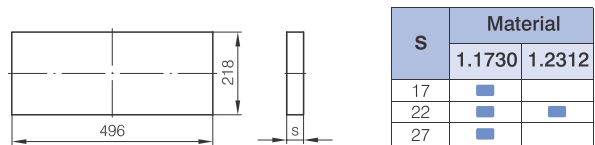

| S  | Material |        |
|----|----------|--------|
|    | 1.1730   | 1.2312 |
| 17 | ■        |        |
| 22 | ■        | ■      |
| 27 | ■        |        |

2193 H

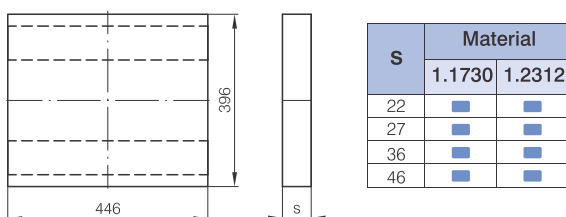

| S  | Material |        |
|----|----------|--------|
|    | 1.1730   | 1.2312 |
| 22 | ■        | ■      |
| 27 | ■        | ■      |
| 36 | ■        | ■      |
| 46 | ■        | ■      |

2193 H

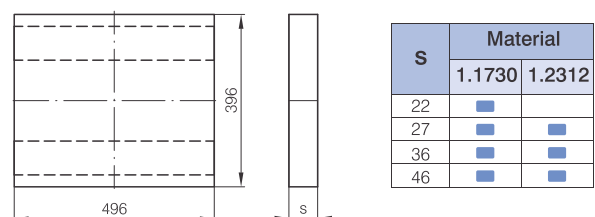

| S  | Material |        |
|----|----------|--------|
|    | 1.1730   | 1.2312 |
| 22 | ■        |        |
| 27 | ■        | ■      |
| 36 | ■        | ■      |
| 46 | ■        | ■      |

## 346 x 546

2190 H

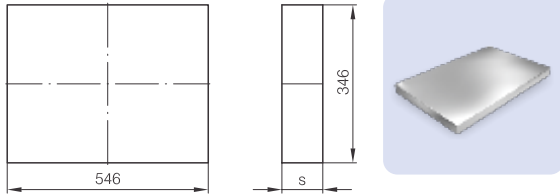

| S   | Material |        |        |        |        |        |        |        |
|-----|----------|--------|--------|--------|--------|--------|--------|--------|
|     | 1.1730   | 1.2162 | 1.2767 | 1.2083 | 1.2085 | 1.2311 | 1.2312 | 1.2343 |
| 22  | ■        |        |        |        |        |        |        |        |
| 27  | ■        |        |        |        | ■      |        | ■      |        |
| 36  | ■        | ■      |        |        | ■      | ■      | ■      |        |
| 46  | ■        | ■      |        |        | ■      | ■      | ■      |        |
| 56  | ■        | ■      |        |        | ■      | ■      | ■      | ■      |
| 66  | ■        |        |        |        | ■      | ■      | ■      |        |
| 76  | ■        | ■      |        |        | ■      | ■      | ■      | ■      |
| 86  | ■        |        |        |        | ■      | ■      | ■      |        |
| 96  | ■        | ■      |        |        | ■      | ■      | ■      | ■      |
| 116 | ■        | ■      |        |        | ■      | ■      | ■      | ■      |
| 136 | ■        | ■      |        |        | ■      | ■      | ■      | ■      |

## 396 x 396

2190 H

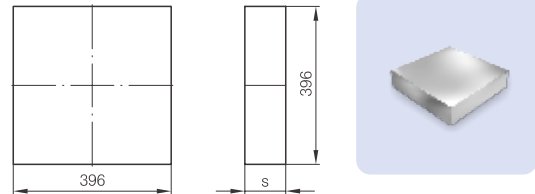

| S   | Material |        |        |        |        |        |        |        |
|-----|----------|--------|--------|--------|--------|--------|--------|--------|
|     | 1.1730   | 1.2162 | 1.2767 | 1.2083 | 1.2085 | 1.2311 | 1.2312 | 1.2343 |
| 17  | ■        |        |        |        |        |        |        |        |
| 22  | ■        | ■      | ■      |        | ■      |        | ■      |        |
| 27  | ■        | ■      | ■      |        | ■      | ■      | ■      |        |
| 36  | ■        | ■      | ■      |        | ■      | ■      | ■      |        |
| 46  | ■        | ■      | ■      |        | ■      | ■      | ■      |        |
| 56  | ■        | ■      | ■      |        | ■      | ■      | ■      | ■      |
| 66  | ■        |        |        |        | ■      |        | ■      |        |
| 76  | ■        | ■      | ■      |        | ■      | ■      | ■      | ■      |
| 86  | ■        |        |        |        | ■      |        | ■      |        |
| 96  | ■        | ■      | ■      |        | ■      | ■      | ■      | ■      |
| 116 | ■        | ■      | ■      |        | ■      | ■      | ■      | ■      |

2191 H



| S   | Material |        |
|-----|----------|--------|
|     | 1.1730   | 1.2312 |
| 66  | ■        |        |
| 76  | ■        |        |
| 86  | ■        |        |
| 96  | ■        |        |
| 116 | ■        |        |
| 136 | ■        |        |

2191 H

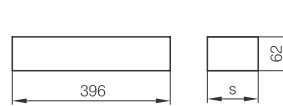

| S   | Material |        |
|-----|----------|--------|
|     | 1.1730   | 1.2312 |
| 56  | ■        |        |
| 66  | ■        |        |
| 76  | ■        |        |
| 86  | ■        |        |
| 96  | ■        |        |
| 116 | ■        |        |

2192 H

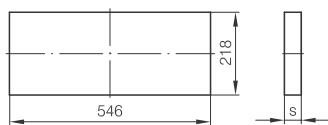

| S  | Material |        |
|----|----------|--------|
|    | 1.1730   | 1.2312 |
| 17 | ■        |        |
| 22 | ■        |        |
| 27 | ■        | ■      |

2192 H

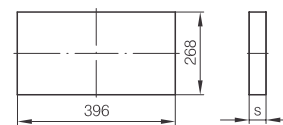

| S  | Material |        |
|----|----------|--------|
|    | 1.1730   | 1.2312 |
| 17 | ■        |        |
| 22 | ■        | ■      |
| 27 | ■        |        |

2193 H

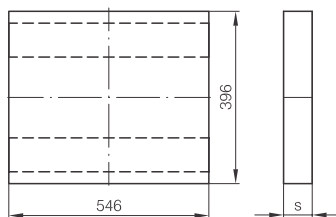

| S  | Material |        |
|----|----------|--------|
|    | 1.1730   | 1.2312 |
| 36 | ■        | ■      |
| 46 | ■        | ■      |
| 56 | ■        | ■      |

2193 H

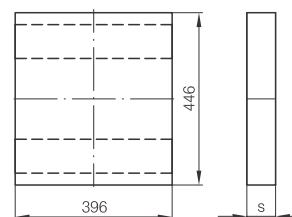

| S  | Material |        |
|----|----------|--------|
|    | 1.1730   | 1.2312 |
| 27 | ■        | ■      |
| 36 | ■        | ■      |
| 46 | ■        | ■      |

## 396 x 446

2190 H

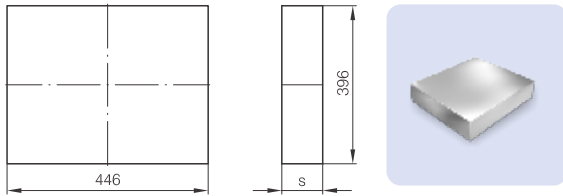

| S   | Material |        |        |        |        |        |        |        |
|-----|----------|--------|--------|--------|--------|--------|--------|--------|
|     | 1.1730   | 1.2162 | 1.2767 | 1.2083 | 1.2085 | 1.2311 | 1.2312 | 1.2343 |
| 22  | ■        |        |        |        | ■      |        | ■      |        |
| 27  | ■        |        |        |        | ■      |        | ■      |        |
| 36  | ■        | ■      |        |        | ■      | ■      | ■      |        |
| 46  | ■        | ■      |        |        | ■      | ■      | ■      |        |
| 56  | ■        | ■      |        |        | ■      | ■      | ■      | ■      |
| 66  | ■        |        |        |        | ■      |        | ■      |        |
| 76  | ■        | ■      |        |        | ■      | ■      | ■      | ■      |
| 86  | ■        |        |        |        | ■      |        | ■      |        |
| 96  | ■        | ■      |        |        | ■      | ■      | ■      | ■      |
| 116 | ■        | ■      |        |        | ■      | ■      | ■      | ■      |

## 396 x 496

2190 H

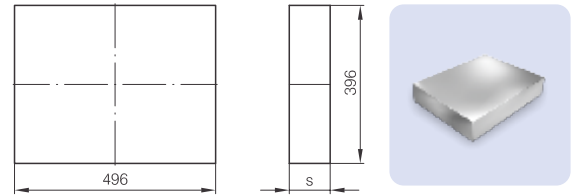

| S   | Material |        |        |        |        |        |        |        |
|-----|----------|--------|--------|--------|--------|--------|--------|--------|
|     | 1.1730   | 1.2162 | 1.2767 | 1.2083 | 1.2085 | 1.2311 | 1.2312 | 1.2343 |
| 22  | ■        |        |        |        | ■      |        | ■      |        |
| 27  | ■        |        |        |        | ■      |        | ■      |        |
| 36  | ■        | ■      |        |        | ■      | ■      | ■      |        |
| 46  | ■        | ■      |        |        | ■      | ■      | ■      |        |
| 56  | ■        | ■      |        |        | ■      | ■      | ■      | ■      |
| 66  | ■        |        |        |        | ■      |        | ■      |        |
| 76  | ■        | ■      |        |        | ■      | ■      | ■      | ■      |
| 86  | ■        |        |        |        | ■      |        | ■      |        |
| 96  | ■        | ■      |        |        | ■      | ■      | ■      | ■      |
| 116 | ■        | ■      |        |        | ■      | ■      | ■      | ■      |
| 136 | ■        | ■      |        |        | ■      | ■      | ■      | ■      |

2191 H



| S   | Material |        |
|-----|----------|--------|
|     | 1.1730   | 1.2312 |
| 56  | ■        |        |
| 66  | ■        |        |
| 76  | ■        |        |
| 86  | ■        |        |
| 96  | ■        |        |
| 116 | ■        |        |

2191 H

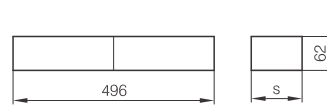

| S   | Material |        |
|-----|----------|--------|
|     | 1.1730   | 1.2312 |
| 56  | ■        |        |
| 66  | ■        |        |
| 76  | ■        |        |
| 86  | ■        |        |
| 96  | ■        |        |
| 116 | ■        |        |
| 136 | ■        |        |

2192 H

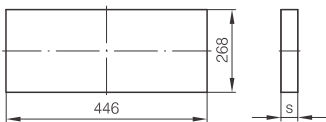

| S  | Material |        |
|----|----------|--------|
|    | 1.1730   | 1.2312 |
| 17 | ■        |        |
| 22 | ■        | ■      |
| 27 | ■        |        |

2192 H

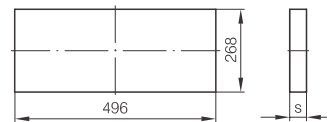

| S  | Material |        |
|----|----------|--------|
|    | 1.1730   | 1.2312 |
| 17 | ■        |        |
| 22 | ■        | ■      |
| 27 | ■        | ■      |

2193 H

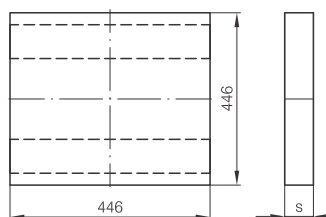

| S  | Material |        |
|----|----------|--------|
|    | 1.1730   | 1.2312 |
| 22 | ■        |        |
| 27 | ■        | ■      |
| 36 | ■        | ■      |
| 46 | ■        | ■      |

2193 H

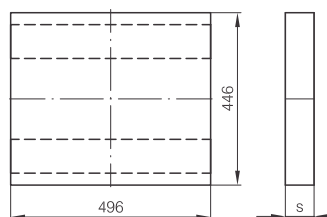

| S  | Material |        |
|----|----------|--------|
|    | 1.1730   | 1.2312 |
| 22 | ■        |        |
| 27 | ■        | ■      |
| 36 | ■        | ■      |
| 46 | ■        | ■      |
| 56 | ■        | ■      |

## 396 x 546

2190 H

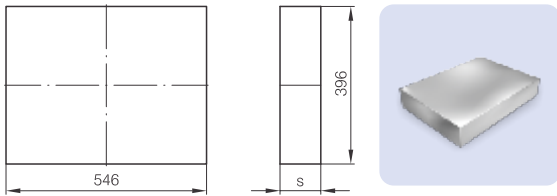

| S   | Material |        |        |        |        |        |        |        |
|-----|----------|--------|--------|--------|--------|--------|--------|--------|
|     | 1.1730   | 1.2162 | 1.2767 | 1.2083 | 1.2085 | 1.2311 | 1.2312 | 1.2343 |
| 17  | ■        |        |        |        |        |        |        |        |
| 22  | ■        |        |        |        |        |        |        |        |
| 27  | ■        | ■      | ■      |        | ■      | ■      | ■      |        |
| 36  | ■        | ■      | ■      |        | ■      | ■      | ■      |        |
| 46  | ■        | ■      | ■      |        | ■      | ■      | ■      |        |
| 56  | ■        | ■      | ■      |        | ■      | ■      | ■      | ■      |
| 66  | ■        |        |        |        | ■      |        | ■      |        |
| 76  | ■        | ■      | ■      |        | ■      | ■      | ■      | ■      |
| 86  | ■        |        |        |        | ■      |        | ■      |        |
| 96  | ■        | ■      | ■      |        | ■      | ■      | ■      | ■      |
| 116 | ■        | ■      | ■      |        | ■      | ■      | ■      | ■      |
| 136 | ■        | ■      | ■      |        | ■      | ■      | ■      | ■      |

## 396 x 596

2190 H

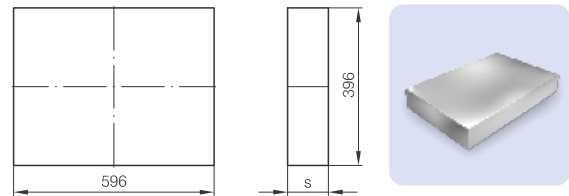

| S   | Material |        |        |        |        |        |        |        |
|-----|----------|--------|--------|--------|--------|--------|--------|--------|
|     | 1.1730   | 1.2162 | 1.2767 | 1.2083 | 1.2085 | 1.2311 | 1.2312 | 1.2343 |
| 22  | ■        |        |        |        |        |        |        |        |
| 27  | ■        |        |        |        | ■      |        | ■      |        |
| 36  | ■        |        |        |        | ■      | ■      | ■      |        |
| 46  | ■        |        |        |        | ■      | ■      | ■      |        |
| 56  | ■        |        |        |        | ■      | ■      | ■      | ■      |
| 66  | ■        |        |        |        | ■      |        | ■      |        |
| 76  | ■        |        |        |        | ■      | ■      | ■      | ■      |
| 86  | ■        |        |        |        | ■      |        | ■      |        |
| 96  | ■        |        |        |        | ■      | ■      | ■      | ■      |
| 116 | ■        |        |        |        | ■      | ■      | ■      | ■      |
| 136 | ■        |        |        |        | ■      | ■      | ■      | ■      |

2191 H

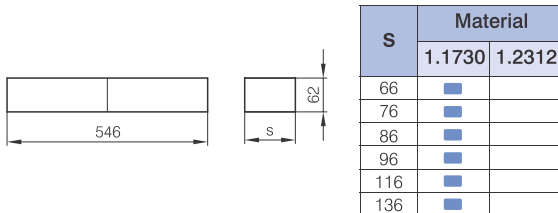

| S   | Material |        |
|-----|----------|--------|
|     | 1.1730   | 1.2312 |
| 66  | ■        |        |
| 76  | ■        |        |
| 86  | ■        |        |
| 96  | ■        |        |
| 116 | ■        |        |
| 136 | ■        |        |

2191 H

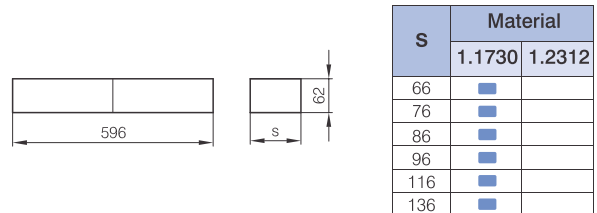

| S   | Material |        |
|-----|----------|--------|
|     | 1.1730   | 1.2312 |
| 66  | ■        |        |
| 76  | ■        |        |
| 86  | ■        |        |
| 96  | ■        |        |
| 116 | ■        |        |
| 136 | ■        |        |

2192 H

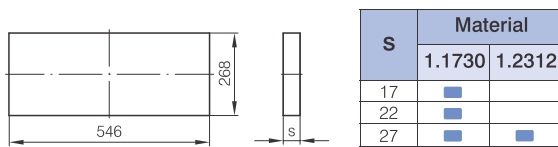

| S  | Material |        |
|----|----------|--------|
|    | 1.1730   | 1.2312 |
| 17 | ■        |        |
| 22 | ■        |        |
| 27 | ■        | ■      |

2192 H

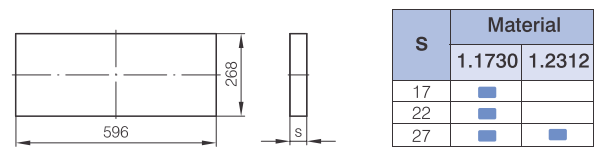

| S  | Material |        |
|----|----------|--------|
|    | 1.1730   | 1.2312 |
| 17 | ■        |        |
| 22 | ■        |        |
| 27 | ■        | ■      |

2193 H

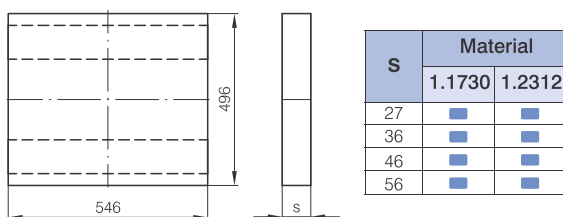

| S  | Material |        |
|----|----------|--------|
|    | 1.1730   | 1.2312 |
| 27 | ■        | ■      |
| 36 | ■        | ■      |
| 46 | ■        | ■      |
| 56 | ■        | ■      |

2193 H

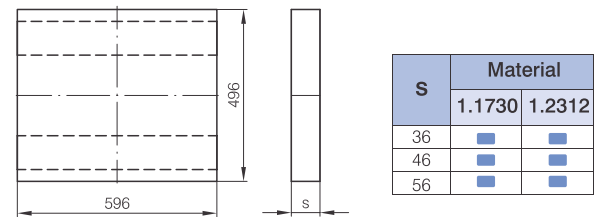

| S  | Material |        |
|----|----------|--------|
|    | 1.1730   | 1.2312 |
| 36 | ■        | ■      |
| 46 | ■        | ■      |
| 56 | ■        | ■      |

## 446 x 446

2190 H

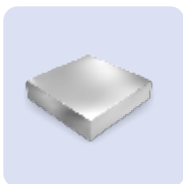
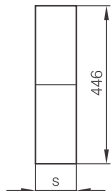
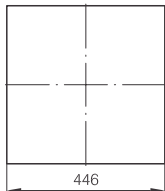

## 446 x 496

2190 H

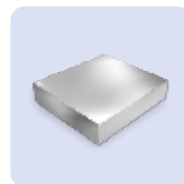
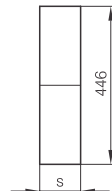
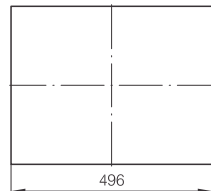

| S   | Material |        |        |        |        |        |        |        |
|-----|----------|--------|--------|--------|--------|--------|--------|--------|
|     | 1.1730   | 1.2162 | 1.2767 | 1.2083 | 1.2085 | 1.2311 | 1.2312 | 1.2343 |
| 22  | ■        | ■      |        |        | ■      | ■      | ■      | ■      |
| 27  | ■        | ■      |        |        | ■      | ■      | ■      | ■      |
| 36  | ■        | ■      |        |        | ■      | ■      | ■      | ■      |
| 46  | ■        | ■      |        |        | ■      | ■      | ■      | ■      |
| 56  | ■        | ■      |        |        | ■      | ■      | ■      | ■      |
| 66  | ■        | ■      |        |        | ■      | ■      | ■      | ■      |
| 76  | ■        | ■      |        |        | ■      | ■      | ■      | ■      |
| 86  | ■        | ■      |        |        | ■      | ■      | ■      | ■      |
| 96  | ■        | ■      |        |        | ■      | ■      | ■      | ■      |
| 116 | ■        | ■      |        |        | ■      | ■      | ■      | ■      |

| S   | Material |        |        |        |        |        |        |        |
|-----|----------|--------|--------|--------|--------|--------|--------|--------|
|     | 1.1730   | 1.2162 | 1.2767 | 1.2083 | 1.2085 | 1.2311 | 1.2312 | 1.2343 |
| 22  | ■        |        |        |        |        |        |        |        |
| 27  | ■        |        |        |        | ■      |        | ■      |        |
| 36  | ■        |        |        |        | ■      | ■      | ■      |        |
| 46  | ■        |        |        |        | ■      | ■      | ■      |        |
| 56  | ■        |        |        |        | ■      | ■      | ■      | ■      |
| 66  | ■        |        |        |        | ■      | ■      | ■      |        |
| 76  | ■        |        |        |        | ■      | ■      | ■      | ■      |
| 86  | ■        |        |        |        | ■      | ■      | ■      |        |
| 96  | ■        |        |        |        | ■      | ■      | ■      | ■      |
| 116 | ■        |        |        |        | ■      | ■      | ■      | ■      |
| 136 | ■        |        |        |        | ■      | ■      | ■      | ■      |

2191 H



| S   | Material |        |
|-----|----------|--------|
|     | 1.1730   | 1.2312 |
| 56  | ■        |        |
| 66  | ■        |        |
| 76  | ■        |        |
| 86  | ■        |        |
| 96  | ■        |        |
| 116 | ■        |        |

2191 H

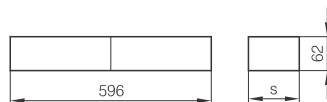

| S   | Material |        |
|-----|----------|--------|
|     | 1.1730   | 1.2312 |
| 56  | ■        |        |
| 66  | ■        |        |
| 76  | ■        |        |
| 86  | ■        |        |
| 96  | ■        |        |
| 116 | ■        |        |
| 136 | ■        |        |

2192 H

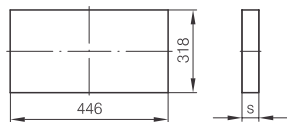

| S  | Material |        |
|----|----------|--------|
|    | 1.1730   | 1.2312 |
| 17 | ■        |        |
| 22 | ■        |        |
| 27 | ■        | ■      |

2192 H

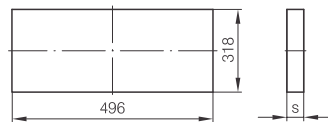

| S  | Material |        |
|----|----------|--------|
|    | 1.1730   | 1.2312 |
| 17 | ■        |        |
| 22 | ■        |        |
| 27 | ■        | ■      |

2193 H

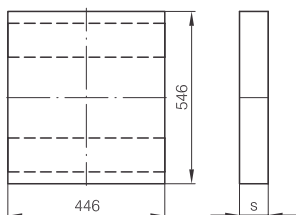

| S  | Material |        |
|----|----------|--------|
|    | 1.1730   | 1.2312 |
| 27 | ■        | ■      |
| 36 | ■        | ■      |
| 46 | ■        | ■      |

2193 H

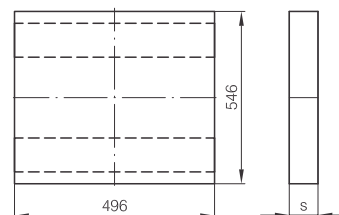

| S  | Material |        |
|----|----------|--------|
|    | 1.1730   | 1.2312 |
| 27 | ■        | ■      |
| 36 | ■        | ■      |
| 46 | ■        | ■      |
| 56 | ■        | ■      |

## 446 x 546

2190 H

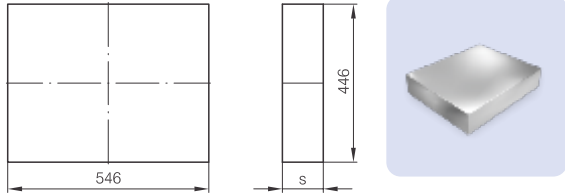

| S   | Material |        |        |        |        |        |        |        |
|-----|----------|--------|--------|--------|--------|--------|--------|--------|
|     | 1.1730   | 1.2162 | 1.2767 | 1.2083 | 1.2085 | 1.2311 | 1.2312 | 1.2343 |
| 27  | ■        |        |        |        | ■      |        | ■      |        |
| 36  | ■        |        |        |        | ■      | ■      | ■      |        |
| 46  | ■        |        |        |        | ■      | ■      | ■      |        |
| 56  | ■        |        |        |        | ■      | ■      |        | ■      |
| 66  | ■        |        |        |        | ■      |        | ■      |        |
| 76  | ■        |        |        |        | ■      | ■      | ■      | ■      |
| 86  | ■        |        |        |        | ■      |        | ■      |        |
| 96  | ■        |        |        |        | ■      | ■      | ■      | ■      |
| 116 | ■        |        |        |        | ■      | ■      | ■      | ■      |
| 136 | ■        |        |        |        | ■      | ■      | ■      | ■      |

## 446 x 596

2190 H

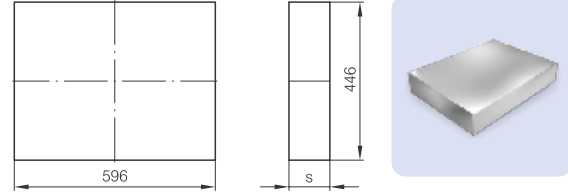

| S   | Material |        |        |        |        |        |        |        |
|-----|----------|--------|--------|--------|--------|--------|--------|--------|
|     | 1.1730   | 1.2162 | 1.2767 | 1.2083 | 1.2085 | 1.2311 | 1.2312 | 1.2343 |
| 27  | ■        |        |        |        | ■      |        | ■      |        |
| 36  | ■        |        |        |        | ■      | ■      | ■      |        |
| 46  | ■        |        |        |        | ■      | ■      | ■      |        |
| 56  | ■        |        |        |        | ■      | ■      | ■      | ■      |
| 66  | ■        |        |        |        | ■      |        | ■      |        |
| 76  | ■        |        |        |        | ■      | ■      | ■      | ■      |
| 86  | ■        |        |        |        | ■      |        | ■      |        |
| 96  | ■        |        |        |        | ■      | ■      | ■      | ■      |
| 116 | ■        |        |        |        | ■      | ■      | ■      | ■      |
| 136 | ■        |        |        |        | ■      | ■      | ■      | ■      |

2191 H

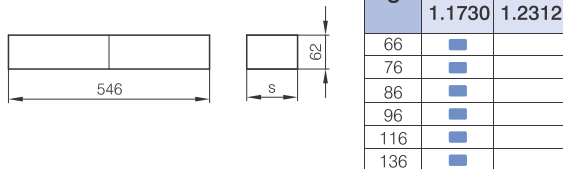

| S   | Material |        |
|-----|----------|--------|
|     | 1.1730   | 1.2312 |
| 66  | ■        |        |
| 76  | ■        |        |
| 86  | ■        |        |
| 96  | ■        |        |
| 116 | ■        |        |
| 136 | ■        |        |

2191 H

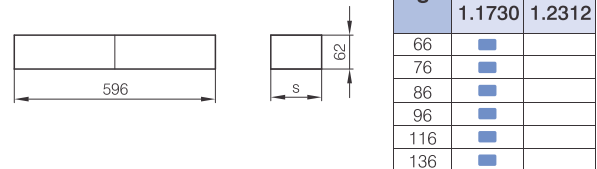

| S   | Material |        |
|-----|----------|--------|
|     | 1.1730   | 1.2312 |
| 66  | ■        |        |
| 76  | ■        |        |
| 86  | ■        |        |
| 96  | ■        |        |
| 116 | ■        |        |
| 136 | ■        |        |

2192 H

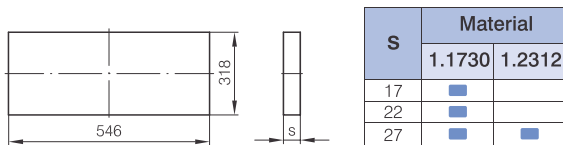

| S  | Material |        |
|----|----------|--------|
|    | 1.1730   | 1.2312 |
| 17 | ■        |        |
| 22 | ■        |        |
| 27 | ■        | ■      |

2192 H

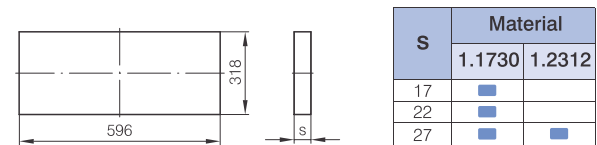

| S  | Material |        |
|----|----------|--------|
|    | 1.1730   | 1.2312 |
| 17 | ■        |        |
| 22 | ■        |        |
| 27 | ■        | ■      |

2193 H

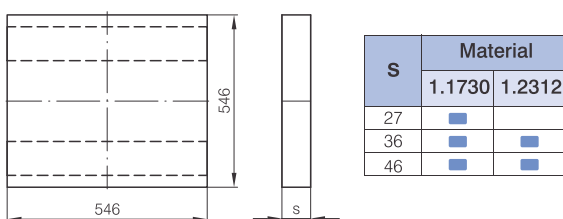

| S  | Material |        |
|----|----------|--------|
|    | 1.1730   | 1.2312 |
| 27 | ■        |        |
| 36 | ■        | ■      |
| 46 | ■        | ■      |

2193 H

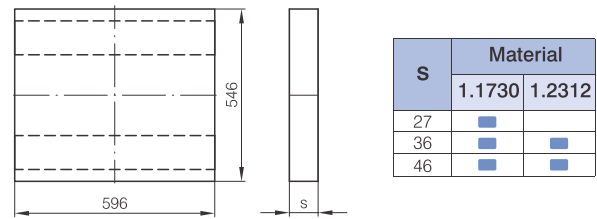

| S  | Material |        |
|----|----------|--------|
|    | 1.1730   | 1.2312 |
| 27 | ■        |        |
| 36 | ■        | ■      |
| 46 | ■        | ■      |

## 496 x 496

2190 H

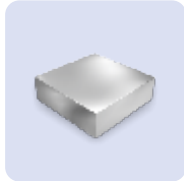
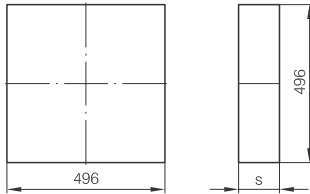

| S   | Material |        |        |        |        |        |        |        |
|-----|----------|--------|--------|--------|--------|--------|--------|--------|
|     | 1.1730   | 1.2162 | 1.2767 | 1.2083 | 1.2085 | 1.2311 | 1.2312 | 1.2343 |
| 27  | ■        |        |        |        | ■      |        | ■      |        |
| 36  | ■        |        |        |        | ■      |        | ■      |        |
| 46  | ■        |        |        |        | ■      | ■      | ■      |        |
| 56  | ■        |        |        |        | ■      | ■      | ■      |        |
| 66  | ■        |        |        |        | ■      | ■      | ■      |        |
| 76  | ■        |        |        |        | ■      | ■      | ■      | ■      |
| 86  | ■        |        |        |        | ■      |        | ■      |        |
| 96  | ■        |        |        |        | ■      | ■      | ■      | ■      |
| 116 | ■        |        |        |        | ■      | ■      | ■      | ■      |
| 136 | ■        |        |        |        | ■      | ■      | ■      | ■      |
| 156 | ■        |        |        |        | ■      | ■      | ■      | ■      |

## 496 x 546

2190 H

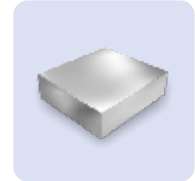
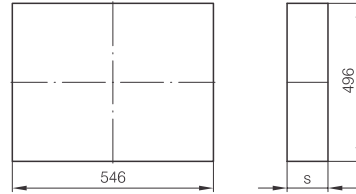

| S   | Material |        |        |        |        |        |        |        |
|-----|----------|--------|--------|--------|--------|--------|--------|--------|
|     | 1.1730   | 1.2162 | 1.2767 | 1.2083 | 1.2085 | 1.2311 | 1.2312 | 1.2343 |
| 27  | ■        |        |        |        | ■      |        | ■      |        |
| 36  | ■        |        |        |        | ■      |        | ■      |        |
| 46  | ■        |        |        |        | ■      | ■      | ■      |        |
| 56  | ■        |        |        |        | ■      | ■      | ■      |        |
| 66  | ■        |        |        |        | ■      | ■      | ■      |        |
| 76  | ■        |        |        |        | ■      | ■      | ■      | ■      |
| 86  | ■        |        |        |        | ■      |        | ■      |        |
| 96  | ■        |        |        |        | ■      | ■      | ■      | ■      |
| 116 | ■        |        |        |        | ■      | ■      | ■      | ■      |
| 136 | ■        |        |        |        | ■      | ■      | ■      | ■      |
| 156 | ■        |        |        |        | ■      | ■      | ■      | ■      |

2191 H



| S   | Material |        |
|-----|----------|--------|
|     | 1.1730   | 1.2312 |
| 66  | ■        |        |
| 76  | ■        |        |
| 86  | ■        |        |
| 96  | ■        |        |
| 116 | ■        |        |
| 136 | ■        |        |

2191 H

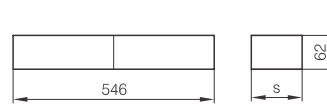

| S   | Material |        |
|-----|----------|--------|
|     | 1.1730   | 1.2312 |
| 66  | ■        |        |
| 76  | ■        |        |
| 86  | ■        |        |
| 96  | ■        |        |
| 116 | ■        |        |
| 136 | ■        |        |

2192 H

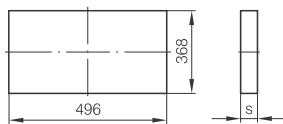

| S  | Material |        |
|----|----------|--------|
|    | 1.1730   | 1.2312 |
| 22 | ■        |        |
| 27 | ■        |        |
| 36 | ■        | ■      |

2192 H

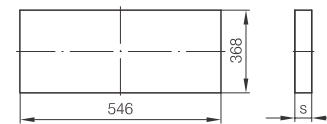

| S  | Material |        |
|----|----------|--------|
|    | 1.1730   | 1.2312 |
| 22 | ■        |        |
| 27 | ■        |        |
| 36 | ■        | ■      |

2193 H

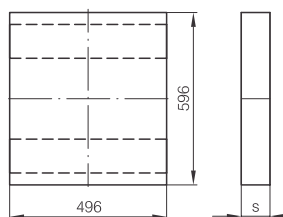

| S  | Material |        |
|----|----------|--------|
|    | 1.1730   | 1.2312 |
| 27 | ■        |        |
| 36 | ■        | ■      |
| 46 | ■        | ■      |
| 56 | ■        | ■      |

2193 H

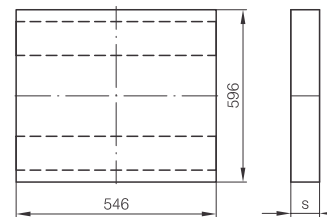

| S  | Material |        |
|----|----------|--------|
|    | 1.1730   | 1.2312 |
| 27 | ■        |        |
| 36 | ■        | ■      |
| 46 | ■        | ■      |
| 56 | ■        | ■      |

## 496 x 596

2190 H

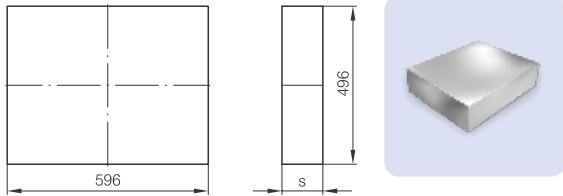

| S   | Material |        |        |        |        |        |        |        |
|-----|----------|--------|--------|--------|--------|--------|--------|--------|
|     | 1.1730   | 1.2162 | 1.2767 | 1.2083 | 1.2085 | 1.2311 | 1.2312 | 1.2343 |
| 27  | ■        |        |        |        |        |        |        |        |
| 36  | ■        |        |        |        | ■      |        | ■      |        |
| 46  | ■        |        |        |        | ■      | ■      | ■      |        |
| 56  | ■        |        |        |        | ■      | ■      | ■      |        |
| 66  | ■        |        |        |        | ■      |        | ■      |        |
| 76  | ■        |        |        |        | ■      | ■      | ■      | ■      |
| 86  | ■        |        |        |        | ■      |        | ■      |        |
| 96  | ■        |        |        |        | ■      | ■      | ■      | ■      |
| 116 | ■        |        |        |        | ■      | ■      | ■      | ■      |
| 136 | ■        |        |        |        | ■      | ■      | ■      | ■      |
| 156 | ■        |        |        |        | ■      | ■      | ■      | ■      |

## 496 x 696

2190 H

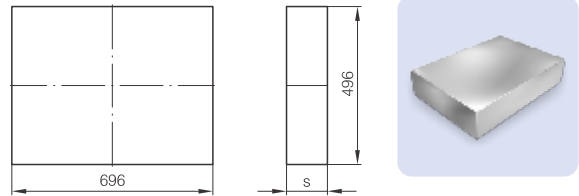

| S   | Material |        |        |        |        |        |        |        |
|-----|----------|--------|--------|--------|--------|--------|--------|--------|
|     | 1.1730   | 1.2162 | 1.2767 | 1.2083 | 1.2085 | 1.2311 | 1.2312 | 1.2343 |
| 27  | ■        |        |        |        |        |        |        |        |
| 36  | ■        |        |        |        | ■      |        | ■      |        |
| 46  | ■        |        |        |        | ■      | ■      | ■      |        |
| 56  | ■        |        |        |        | ■      | ■      | ■      |        |
| 66  | ■        |        |        |        | ■      |        | ■      |        |
| 76  | ■        |        |        |        | ■      | ■      | ■      | ■      |
| 86  | ■        |        |        |        | ■      |        | ■      |        |
| 96  | ■        |        |        |        | ■      | ■      | ■      | ■      |
| 116 | ■        |        |        |        | ■      | ■      | ■      | ■      |
| 136 | ■        |        |        |        | ■      | ■      | ■      | ■      |
| 156 | ■        |        |        |        | ■      | ■      | ■      | ■      |

2191 H

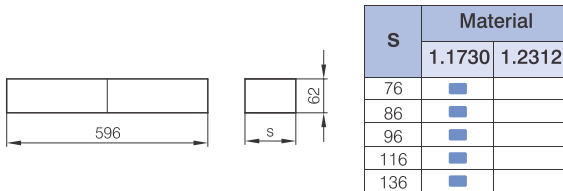

| S   | Material |        |
|-----|----------|--------|
|     | 1.1730   | 1.2312 |
| 76  | ■        |        |
| 86  | ■        |        |
| 96  | ■        |        |
| 116 | ■        |        |
| 136 | ■        |        |

2191 H

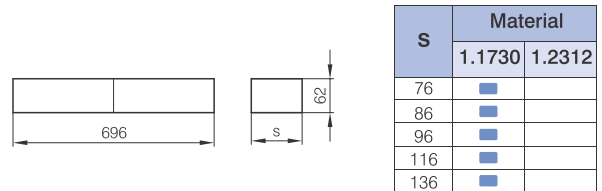

| S   | Material |        |
|-----|----------|--------|
|     | 1.1730   | 1.2312 |
| 76  | ■        |        |
| 86  | ■        |        |
| 96  | ■        |        |
| 116 | ■        |        |
| 136 | ■        |        |

2192 H

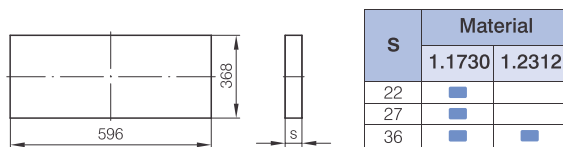

| S  | Material |        |
|----|----------|--------|
|    | 1.1730   | 1.2312 |
| 22 | ■        |        |
| 27 | ■        |        |
| 36 | ■        | ■      |

2192 H

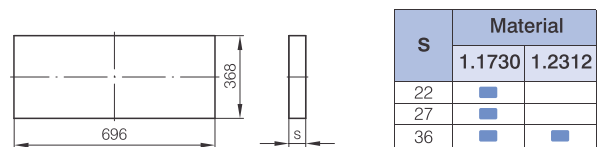

| S  | Material |        |
|----|----------|--------|
|    | 1.1730   | 1.2312 |
| 22 | ■        |        |
| 27 | ■        |        |
| 36 | ■        | ■      |

2193 H

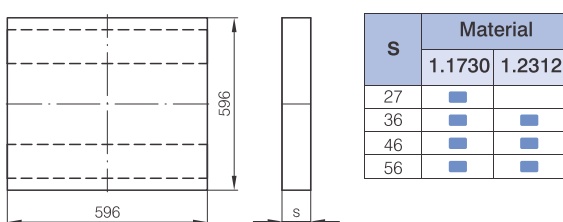

| S  | Material |        |
|----|----------|--------|
|    | 1.1730   | 1.2312 |
| 27 | ■        |        |
| 36 | ■        | ■      |
| 46 | ■        | ■      |
| 56 | ■        | ■      |

2193 H

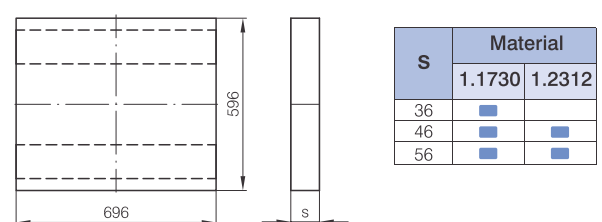

| S  | Material |        |
|----|----------|--------|
|    | 1.1730   | 1.2312 |
| 36 | ■        |        |
| 46 | ■        | ■      |
| 56 | ■        | ■      |

## 546 x 546

2190 H

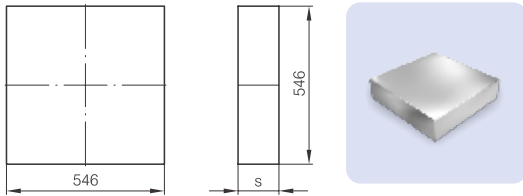

| S   | Material |        |        |        |        |        |        |        |
|-----|----------|--------|--------|--------|--------|--------|--------|--------|
|     | 1.1730   | 1.2162 | 1.2767 | 1.2083 | 1.2085 | 1.2311 | 1.2312 | 1.2343 |
| 27  | ■        |        |        |        |        |        |        |        |
| 36  | ■        |        |        |        | ■      |        | ■      |        |
| 46  | ■        |        |        |        | ■      | ■      | ■      |        |
| 56  | ■        |        |        |        | ■      | ■      | ■      |        |
| 66  | ■        |        |        |        | ■      | ■      | ■      |        |
| 76  | ■        |        |        |        | ■      | ■      | ■      | ■      |
| 86  | ■        |        |        |        | ■      |        | ■      |        |
| 96  | ■        |        |        |        | ■      | ■      | ■      | ■      |
| 116 | ■        |        |        |        | ■      | ■      | ■      | ■      |
| 136 | ■        |        |        |        | ■      | ■      | ■      | ■      |
| 156 | ■        |        |        |        | ■      | ■      | ■      | ■      |

## 546 x 596

2190 H

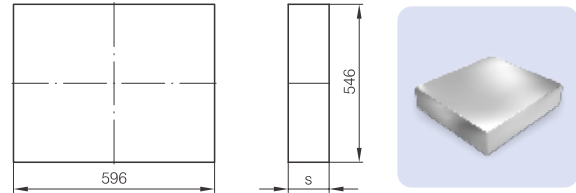

| S   | Material |        |        |        |        |        |        |        |
|-----|----------|--------|--------|--------|--------|--------|--------|--------|
|     | 1.1730   | 1.2162 | 1.2767 | 1.2083 | 1.2085 | 1.2311 | 1.2312 | 1.2343 |
| 27  | ■        |        |        |        |        |        |        |        |
| 36  | ■        |        |        |        | ■      |        | ■      |        |
| 46  | ■        |        |        |        | ■      | ■      | ■      |        |
| 56  | ■        |        |        |        | ■      | ■      | ■      |        |
| 66  | ■        |        |        |        | ■      | ■      | ■      |        |
| 76  | ■        |        |        |        | ■      | ■      | ■      | ■      |
| 86  | ■        |        |        |        | ■      |        | ■      |        |
| 96  | ■        |        |        |        | ■      | ■      | ■      | ■      |
| 116 | ■        |        |        |        | ■      | ■      | ■      | ■      |
| 136 | ■        |        |        |        | ■      | ■      | ■      | ■      |
| 156 | ■        |        |        |        | ■      | ■      | ■      | ■      |

2191 H



| S   | Material |        |
|-----|----------|--------|
|     | 1.1730   | 1.2312 |
| 76  | ■        |        |
| 86  | ■        |        |
| 96  | ■        |        |
| 116 | ■        |        |
| 136 | ■        |        |

2191 H

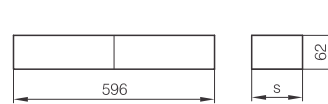

| S   | Material |        |
|-----|----------|--------|
|     | 1.1730   | 1.2312 |
| 76  | ■        |        |
| 86  | ■        |        |
| 96  | ■        |        |
| 116 | ■        |        |
| 136 | ■        |        |

2192 H

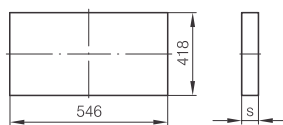

| S  | Material |        |
|----|----------|--------|
|    | 1.1730   | 1.2312 |
| 22 | ■        |        |
| 27 | ■        |        |
| 36 | ■        | ■      |

2192 H

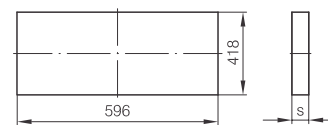

| S  | Material |        |
|----|----------|--------|
|    | 1.1730   | 1.2312 |
| 22 | ■        |        |
| 27 | ■        |        |
| 36 | ■        | ■      |

2193 H

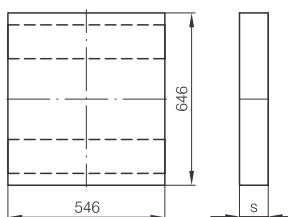

| S  | Material |        |
|----|----------|--------|
|    | 1.1730   | 1.2312 |
| 36 | ■        | ■      |
| 46 | ■        | ■      |
| 56 | ■        | ■      |

2193 H

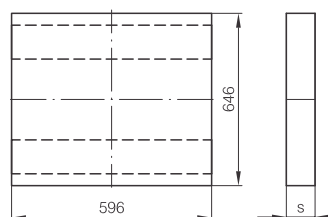

| S  | Material |        |
|----|----------|--------|
|    | 1.1730   | 1.2312 |
| 36 | ■        | ■      |
| 46 | ■        | ■      |
| 56 | ■        | ■      |

## 596 x 596

### 2190 H

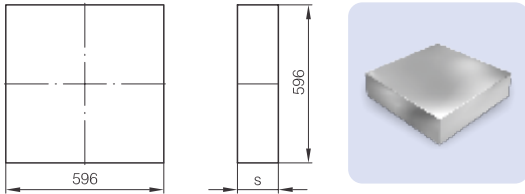

| S   | Material |        |        |        |        |        |        |        |
|-----|----------|--------|--------|--------|--------|--------|--------|--------|
|     | 1.1730   | 1.2162 | 1.2767 | 1.2083 | 1.2085 | 1.2311 | 1.2312 | 1.2343 |
| 27  | ■        |        |        |        |        |        |        |        |
| 36  | ■        |        |        |        | ■      |        | ■      |        |
| 46  | ■        |        |        |        | ■      | ■      | ■      |        |
| 56  | ■        |        |        |        | ■      | ■      | ■      |        |
| 66  | ■        |        |        |        | ■      |        | ■      |        |
| 76  | ■        |        |        |        | ■      | ■      | ■      | ■      |
| 86  | ■        |        |        |        | ■      |        | ■      |        |
| 96  | ■        |        |        |        | ■      | ■      | ■      | ■      |
| 116 | ■        |        |        |        | ■      | ■      | ■      | ■      |
| 136 | ■        |        |        |        | ■      | ■      | ■      | ■      |
| 156 | ■        |        |        |        | ■      | ■      | ■      | ■      |

### 2191 H

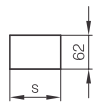
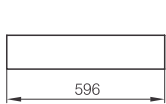

| S   | Material |        |
|-----|----------|--------|
|     | 1.1730   | 1.2312 |
| 76  | ■        |        |
| 86  | ■        |        |
| 96  | ■        |        |
| 116 | ■        |        |
| 136 | ■        |        |

### 2192 H

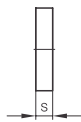
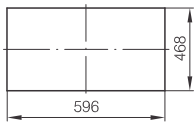

| S  | Material |        |
|----|----------|--------|
|    | 1.1730   | 1.2312 |
| 22 | ■        |        |
| 27 | ■        |        |
| 36 | ■        | ■      |

### 2193 H

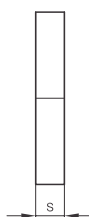
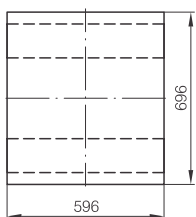

| S  | Material |        |
|----|----------|--------|
|    | 1.1730   | 1.2312 |
| 36 | ■        | ■      |
| 46 | ■        | ■      |
| 56 | ■        | ■      |

### 2195 H

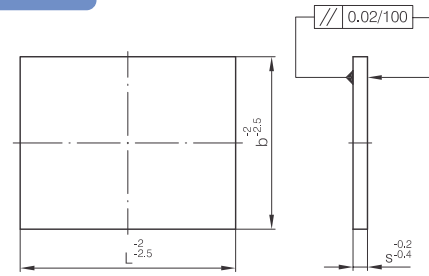

Mat.: Synthetic resin  
 $\lambda = 0,18 \text{ W/mK}$   
 Temp.: max. 230°C



### 2195 H - b x l x s

| b   | L   | s        |          |
|-----|-----|----------|----------|
| 156 | 156 | 3<br>5   |          |
|     | 196 | 196      | 3<br>5   |
|     |     | 246      | 3<br>5   |
| 196 | 196 | 3<br>5   |          |
|     | 246 | 246      | 3<br>5   |
|     |     | 296      | 5<br>7   |
| 246 | 246 | 5<br>7   |          |
|     | 296 | 296      | 5<br>7   |
|     |     | 346      | 5<br>7   |
|     | 396 | 5<br>7   |          |
| 296 | 296 | 7<br>8,5 |          |
|     | 346 | 346      | 7<br>8,5 |
|     |     | 396      | 7<br>8,5 |
|     | 446 | 7<br>8,5 |          |
| 346 | 346 | 7<br>8,5 |          |
|     | 396 | 396      | 7<br>8,5 |
|     |     | 446      | 7<br>8,5 |
|     | 496 | 496      | 7<br>8,5 |
|     |     | 546      | 7<br>8,5 |
| 596 |     | 7<br>8,5 |          |
| 396 | 396 | 7<br>8,5 |          |
|     | 446 | 446      | 7<br>8,5 |
|     |     | 496      | 7<br>8,5 |
|     | 546 | 546      | 7<br>8,5 |
|     |     | 596      | 7<br>8,5 |
| 696 |     | 7<br>8,5 |          |
| 446 | 446 | 8,5      |          |
|     | 496 | 8,5      |          |
|     | 546 | 8,5      |          |
|     | 596 | 8,5      |          |
| 496 | 496 | 8,5      |          |
|     | 546 | 8,5      |          |
|     | 596 | 8,5      |          |
| 546 | 546 | 8,5      |          |
|     | 596 | 8,5      |          |
| 596 | 596 | 8,5      |          |

